

# Operating Instructions

**Selectiva 4.0**

2 - 3 kW

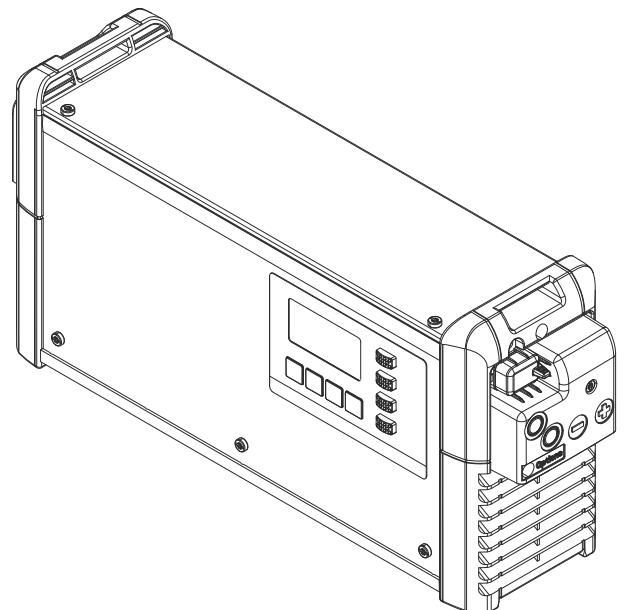

**EN-US** | Operating instructions



42,0426,0357,EA

010-17082022



# Table of contents

Power categories.....	5
General.....	5
2 kW.....	5
3 kW.....	5
Safety Instructions.....	6
General.....	6
Environmental conditions.....	6
Grid connection.....	6
Dangers due to Grid and Charging Current.....	7
Danger due to Acids, Gases, and Vapors.....	7
General information on working with batteries.....	7
Personal Protection and Protection of Others.....	8
Safety Measures in Normal Operation.....	8
EMC device classifications.....	8
EMC Measures.....	8
Data backup.....	9
Maintenance.....	9
Repair.....	9
Obligations of the operating company.....	9
Safety Inspection.....	9
Markings on the device.....	9
Disposal.....	9
Copyright.....	10
General information.....	11
Explanation of Safety Instructions.....	11
Device concept.....	11
Intended use.....	11
Grid connection.....	12
Charging cables.....	13
Correct routing of the mains/charging cables.....	13
Warning notices on the device.....	14
Warning notices inside the device.....	15
Setup regulations.....	15
Wall and floor mounting.....	17
Operating controls and connections.....	20
Operating controls and connections.....	20
Pin assignment for 2 kW optional plug.....	21
Pin assignment for 3 kW optional plug.....	22
Control panel.....	24
Charging the battery.....	26
Starting for the first time.....	26
Charging process.....	27
Interrupting the charging process.....	29
Ending the charging process.....	30
Display.....	32
Overview of display modes.....	32
Standard mode.....	32
Menu selection.....	33
Statistics mode.....	33
History mode.....	34
Configuration mode.....	35
Settings.....	38
Electrolyte circulation.....	39
Temperature-controlled charging.....	40
Equalizing charge.....	41
Delay.....	42
Calendar.....	42
Special charges.....	44
Special function - opportunity charging.....	45
DC connection.....	45

Additional functions .....	46
General options.....	48
Reset settings.....	49
USB mode.....	50
Status codes.....	51
Options.....	56
Safety.....	56
3 kW electrolyte circulation.....	56
External start/stop.....	58
Temperature-controlled charging.....	58
LED strip.....	58
Air filter.....	59
Wall and floor bracket.....	59
"Mobile" set.....	59
Option box.....	59
Mounting plate.....	59
Remote control system.....	60
Gateway Link.....	60
Gateway.....	60
Technical data.....	61
Selectiva 2 kW.....	61
Selectiva 3 kW.....	62

# Power categories

---

**General**                    The kW specification for the power categories refers to the housing design and is not directly related to the actual device power.

---

**2 kW**                      Selectiva  
2040 / 2050 / 2060 / 2070  
4020 / 4035

---

**3 kW**                      Selectiva  
2080 / 2100 / 2120  
4045 / 4060

# Safety Instructions

---

## General

The device has been manufactured using state-of-the-art technology and according to recognized safety standards. If used incorrectly or misused, however, it can cause

- injury or death to the operator or a third party
  - damage to the device and other material assets belonging to the operating company
  - inefficient operation of the equipment
- 

All persons involved in the commissioning, operation, maintenance, and servicing of the device must

- be suitably qualified
  - have completely read and followed these operating instructions
- 

The operating instructions must always be at hand wherever the device is being used. In addition to the operating instructions, all applicable local rules and regulations regarding accident prevention and environmental protection must also be followed.

---

All safety and danger notices on the device

- must be kept in a legible state,
  - must not be damaged/marked,
  - must not be removed,
  - must not be covered, pasted, or painted over.
- 

For the location of the safety and danger notices on the device, refer to the section headed "General Information" in the operating instructions for the device. Before switching on the device, eliminate any faults that could compromise safety.

**Your personal safety is at stake!**

---

## Environmental conditions

Operation or storage of the device outside the stipulated area will be deemed as not in accordance with the intended purpose. The manufacturer accepts no liability for any damage resulting from improper use.

---

For exact information on permitted environmental conditions, please refer to the "Technical data" chapter.

---

## Grid connection

Devices with a high output can influence the energy quality of the grid due to their current consumption.

---

This may affect a number of device types in terms of:

- Connection restrictions, requirements regarding maximum permissible grid impedance \*) or
- criteria regarding the minimum required short circuit power \*)

\*) both at the interface with the public grid  
See technical data

---

In this case, the operator or the person using the device should check whether or not the device is allowed to be connected, where appropriate through discussion with the grid operator.

**IMPORTANT!** Ensure secure grounding of the grid connection.

**Dangers due to Grid and Charging Current**

- Work with battery charging systems poses a number of dangers, such as:
- electrical hazard due to grid and charging current.
  - hazardous electromagnetic fields that may pose a risk of death for individuals with pacemakers.

An electric shock can be fatal. Every electric shock poses a risk of death. To prevent electric shock during operation:

- do not touch any voltage-carrying parts inside or outside of the device.
- never touch the battery poles.
- do not short-circuit the charging cable or charging terminals.

All cables and leads must be secured, undamaged, insulated, and adequately dimensioned. Loose connections, scorched, damaged, or under-dimensioned cables and leads must be repaired immediately by an authorized specialist.

**Danger due to Acids, Gases, and Vapors**

Batteries contain acids which pose a risk to the eyes and skin. Furthermore, charging batteries produces gases and vapors that may be hazardous to your health and are highly explosive under certain circumstances.

Only use battery charging systems in well ventilated rooms in order to prevent the accumulation of explosive gases. Battery rooms are not considered at risk of explosion if a hydrogen concentration of less than 4% is guaranteed by natural or artificial ventilation.

During charging observe a minimum distance of 0.5 m (19.69 in.) between the battery and charging system. Keep potential sources of ignition such as fire and open flames away from the battery.

Never disconnect the battery (e.g., charging terminals) during charging.

Never breathe in the gases and vapors produced by the battery - Ensure there is a sufficient supply of fresh air.

Do not place any tools or electrically conductive metals on the battery, in order to prevent short circuits.

Never allow battery acid to come into contact with your eyes, skin, or clothing. Wear eye protection and appropriate protective clothing. Rinse away any splashed acid immediately and thoroughly with clean water, and consult a physician if necessary.

**General information on working with batteries**

- Protect batteries from dirt and mechanical damage.
- Store charged batteries in cool rooms. The lowest self discharge occurs at approx. +2°C (35.6°F).
- Refer to the specifications of the battery manufacturer or conduct weekly visual inspections to ensure that the battery is filled with acid (electrolyte) up to the maximum marking.
- Do not start operating the device, or immediately stop operation, and have the battery inspected by an authorized specialist if:
  - the acid level is uneven or there is high water consumption in individual cells caused by a possible defect
  - the battery heats up to an impermissible level, above 55°C (131°F)

---

**Personal Protection and Protection of Others**

Keep persons, especially children, away from the device and working area during operation. If persons are in the vicinity, however:

- inform them of any dangers (hazardous acids and gases, risk due to grid and charging current, etc.)
- provide suitable protective equipment

Before leaving the working area, ensure that no personal injury or property damage can occur in your absence.

---

**Safety Measures in Normal Operation**

Operate devices with ground conductors only on a grid with a ground conductor and a socket with a ground conductor contact. Operating the device on a grid without a ground conductor or on a socket without a ground conductor contact is considered gross negligence. The manufacturer is not responsible for any damage resulting from improper use.

---

Only operate the device in accordance with the degree of protection shown on the rating plate.

---

Never commission the device if it is damaged.

---

Have the grid and device supply lead regularly inspected by an electrician to ensure that the ground conductor is functioning properly.

---

Safety devices that are not fully functional and components with defects must be repaired by an authorized specialist before the device is turned on.

---

Never bypass or disable protection devices.

---

A freely accessible mains plug is required after installation.

---

**EMC device classifications**

Devices in emission class A:

- Are only designed for use in industrial areas
  - Can cause wiring-related or radiated interference in other areas.
- 

Devices in emission class B:

- Satisfy the emissions criteria for residential and industrial areas. This is also true for residential areas in which the energy is supplied from the public low-voltage grid.
- 

EMC device classification as per the rating plate or technical data.

---

**EMC Measures**

In certain cases, even though a device complies with the standard limit values for emissions, it may affect the application area for which it was designed (e.g., when there is sensitive equipment at the same location, or if the site where the device is installed is close to either radio or television receivers).

If this is the case, then the operating company is obliged to take appropriate action to rectify the situation.



<b>Data backup</b>	The user is responsible for backing up any changes made to the factory settings. The manufacturer accepts no liability for any deleted personal settings.
<b>Maintenance</b>	Check the mains plug, mains cable, charging lead, and charging terminals for damage before each commissioning. If dirt accumulates on the device, clean the surface of the device housing with a soft cloth and only with solvent-free cleaning agents.
<b>Repair</b>	Repair work must only be carried out by authorized personnel. Use only original spare and wearing parts (also applies to standard parts). It is impossible to guarantee that third-party parts are designed and manufactured to meet the demands made on them, or that they satisfy safety requirements. <hr/> Do not carry out any alterations, installations, or modifications to the device without first obtaining the manufacturer's permission.
<b>Obligations of the operating company</b>	The operating company must only allow persons to work with the device if they <ul style="list-style-type: none"> <li>- are familiar with the basic occupational safety and accident prevention regulations and are trained in handling the device</li> <li>- have read and understood these Operating Instructions, especially the "Safety rules" section, and have confirmed this with their signature</li> <li>- are trained according to the requirements for the work results.</li> </ul> <hr/> The safety-conscious work of the personnel must be checked regularly.
<b>Safety Inspection</b>	The manufacturer recommends that a safety inspection of the device be performed at least every 12 months. <hr/> A safety inspection by a certified electrician is recommended <ul style="list-style-type: none"> <li>- after changes,</li> <li>- after alterations,</li> <li>- after repair, service and maintenance,</li> <li>- at least every 12 months.</li> </ul> <hr/> For the safety inspection, follow the appropriate national and international standards and guidelines. <hr/> You can obtain more information about the safety inspection from your service center. The service center will provide the necessary documents upon request.
<b>Markings on the device</b>	Devices bearing the CE label satisfy the essential requirements of applicable directives. <hr/> Devices bearing the EAC mark of conformity satisfy the requirements of the relevant standards for Russia, Belarus, Kazakhstan, Armenia, and Kyrgyzstan.
<b>Disposal</b>	To comply with European directives and national law, waste electrical and electronic equipment must be collected separately and sent for environmentally-friendly recycling. Used devices must be returned to a distributor or an approved

collection and recycling facility in your area. Proper disposal of used devices promotes the sustainable recycling of material resources. Ignoring this may have potentially adverse effects on the environment and your health.

**Packaging materials**

Materials collected separately. Check the regulations in your area. Reduce the volume of cardboard.

---

**Copyright**

Copyright of these Operating Instructions remains with the manufacturer.

---

Text and illustrations were accurate at the time of printing. Fronius reserves the right to make changes. The contents of the Operating Instructions shall not provide the basis for any claims whatsoever on the part of the purchaser. If you have any suggestions for improvement, or can point out any mistakes that you have found in the Operating Instructions, we will be most grateful for your comments.

# General information

## Explanation of Safety Instructions

### **DANGER!**

Indicates an immediate danger.

- ▶ Death or serious injury may result if appropriate precautions are not taken.

### **WARNING!**

Indicates a possibly dangerous situation.

- ▶ Death or serious injury may result if appropriate precautions are not taken.

### **CAUTION!**

Indicates a situation where damage or injury could occur.

- ▶ Minor injury or damage to property may result if appropriate precautions are not taken.

### **NOTE!**

Indicates the possibility of flawed results and damage to the equipment.

## Device concept

The battery charging systems in the single-phase range for 24 V and 48 V batteries are characterized by intelligent charging technology. The successful Active Inverter Technology with the revolutionary Ri charging process adapts to the needs of the battery and only charges the current that is really needed into the battery.

The technology is embedded in a sturdy industry-standard housing. The extremely compact design meets all requirements for safety standards, reduces space requirements and protects the parts for a long service life.

Equipped with a graphic display, an integrated data logger, new interfaces and additional options, the device is perfectly equipped for the future.

## Intended use

The battery charger is intended to charge the following listed batteries. Any other use is deemed to be not in accordance with the intended purpose. The manufacturer shall not be liable for any damage resulting from such improper use. Intended use also means

- Following all the instructions in these Operating Instructions
- Regularly checking the grid and charging cable

### **WARNING!**

**Danger from charging dry batteries (primary cells) and non-rechargeable batteries.**

This can result in severe personal injury and damage to property.

- ▶ Only charge the types of battery listed below.

 **WARNING!**

**Danger from unsuitable batteries connected to the battery charger.**

Serious personal injury and property damage as a result of escaping gases, ignition or explosion may result.

- ▶ Only connect batteries to the battery charger which are suitable for the battery charger in terms of their type, voltage and capacity and which correspond to the settings on the battery charger.

---

The battery charger is designed for charging lead-acid batteries and NiCd batteries. Set the battery charger to the type of battery to be charged:

- Pb-WET batteries (PzS, GiS, ...):  
Venting, closed lead-acid wet batteries with liquid electrolyte.
- Pb-GEL batteries (PzV, GiV, ...):  
Valve-regulated, sealed lead-acid batteries (VRLA) with fixed electrolyte (gel or fleece).
- NiCd batteries:  
Closed or sealed NiCd batteries with liquid electrolyte.
- Pb-CSM-WET batteries (Copper Strained Metal):  
Closed lead-acid CSM batteries with liquid electrolyte.
- Lead Crystal batteries:  
Type EVFJ/CNFJ Lead Crystal batteries.

The device must be handled correctly in order for it to work. Never pull on the cable when handling the device.

---

**Grid connection**

 **WARNING!**

**Danger from electrical current.**

This may result in serious injuries or death.

- ▶ Before starting work, switch off all devices and components involved, and disconnect them from the grid.
- ▶ Secure all devices and components involved so they cannot be switched back on.

---

 **WARNING!**

**Danger from incorrect operation and work that is not carried out properly.**

This can result in severe personal injury and damage to property.

- ▶ All the work and functions described in this document must only be carried out by trained and qualified personnel.
- ▶ Read and understand this document.
- ▶ Read and understand all the Operating Instructions for the system components, especially the safety rules.

---

 **WARNING!**

**Danger due to faulty or insufficient grid power supply.**

This can result in severe personal injury and damage to property.

- ▶ The requirements for the grid power supply according to the "Technical data" chapter must be fulfilled.
-

Charging cables

**⚠ WARNING!**

**Danger due to charging cables lying around.**

This can result in severe personal injury and damage to property. Personnel can get caught or trip on unplugged, loose cables

- ▶ Lay charging cables so that no one can trip over them or get caught on them.

**⚠ WARNING!**

**Danger if the active charging process is interrupted by disconnecting the charging plug.**

This can result in severe personal injury and damage to property. The resulting sparks can ignite the charging gases that form during charging and cause a fire or explosion

- ▶ When charging is complete, wind up the charging cables or place them on the cable holder, if available.

Correct routing of the mains/charging cables

**⚠ CAUTION!**

**Danger due to overheating as a result of incorrectly laid mains/charging cables.**

Risk of damage to the components.

- ▶ Lay the mains/charging cable without a loop.
- ▶ Do not cover the mains/charging cable.
- ▶ Charging cables longer than 5 m (16 ft. 4.85 in.) must be laid individually (no bundling).
- ▶ Charging cables longer than 5 m (16 ft. 4.85 in.) can have an increased surface temperature (be aware of hot surfaces).
- ▶ In the following cases, pay special attention that the surface temperature of the charging cables does not exceed 80 °C (176 °F):
  - Ambient temperature is 30 °C (86 °F) or more
  - Cross-section of the charging cable is 95 mm<sup>2</sup> or more
  - Length of the charging cable is 5 m (16 ft. 4.85 in.) or more
- ▶ The mains/charging cable may only be replaced by a qualified electrician.

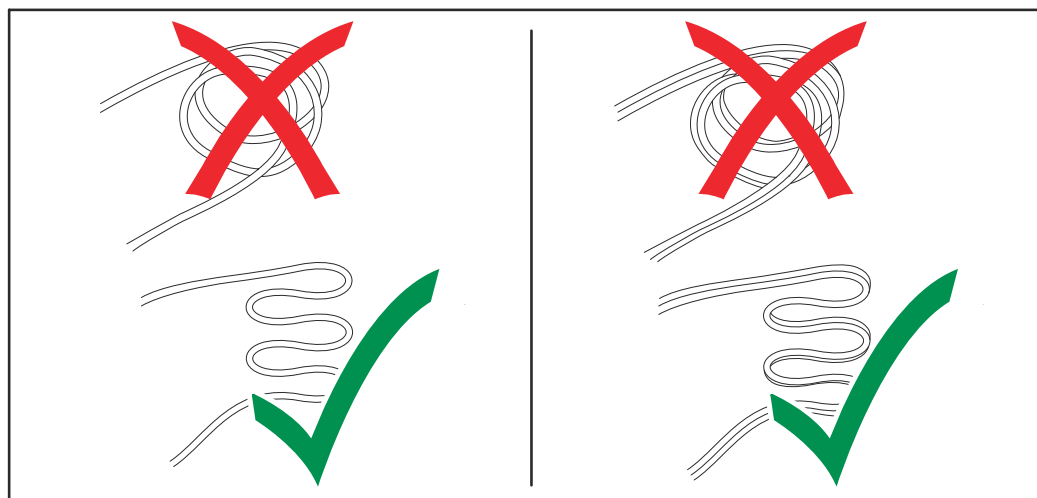

**Warning notices on the device**

The battery charger features safety symbols on the rating plate. The safety symbols must not be removed or painted over.

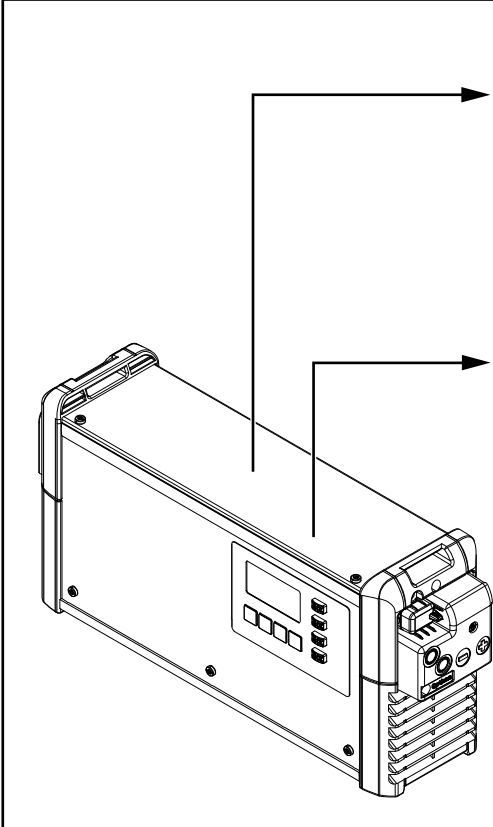

**WARNING - WARNING - ATTENTION**  
**ADVERTENCIA - AVVISO**

Ladevorgang immer stoppen bevor das Ladekabel abgezogen wird!  
 Explosive Gase, Flammen und Funken vermeiden.  
 Während des Ladens für ausreichend Frischluft-Zufuhr sorgen!

Always stop charging before you disconnect the charging cable!  
 Explosive gases. Prevent flames and sparks.  
 Provide adequate ventilation during charge!

Toujours arrêter la charge avant de déconnecter le câble de charge!  
 Gaz explosifs. Éviter les flammes et les étincelles.  
 Prévoir une ventilation adaptée pendant la charge!

¡Detener siempre la carga antes de desconectar el cable de carga!  
 Gases explosivos. Evitar llamas y chipas.  
 ¡Mantener una ventilación adecuada durante la carga!

Interrompere sempre la carica prima di scollegare il cavo di carica!  
 Gas esplosivi. Evitare fiamme libere e scintille.  
 Predisporre una ventilazione adeguata durante la carica!

42,0409,0419

www.fronius.com		Selectiva x.0 xxxx xkW	
		Part No.:	4,010,xxx
		Ser. No.:	xxxxxxx
	U <sub>AC</sub> nom.	1~ NPE 230V 50/60Hz	
	I <sub>AC</sub> max.	xxA	
	P <sub>AC</sub> max.	xxxxW	
	U <sub>DC</sub> nom.	xxV	
	I <sub>DC</sub> max.	xxA	
IP21	Protective class I		
Fronius International GmbH Froniusstraße 1 4643 Pettenbach Austria			XXX



Dispose of old devices in accordance with safety rules and not in normal domestic waste.



Keep potential sources of ignition such as fire, sparks, and open flames away from the battery.



Danger of explosion! Oxyhydrogen forms in the battery during charging.



Battery acid is corrosive and must never come into contact with your eyes, skin or clothing.



Ensure there is a sufficient supply of fresh air during charging.



Use functions only after reading the Operating Instructions in full.

**Warning notices inside the device**



**⚠ WARNING!**



**Danger of electric shock.**

This may result in serious injuries or death.

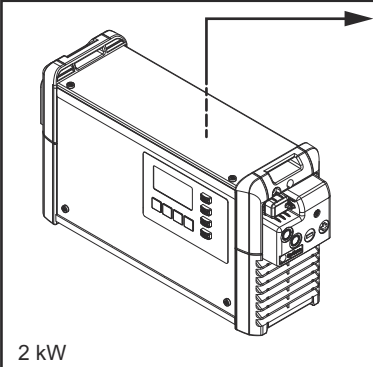
- ▶ The housing may only be opened by service technicians trained by the manufacturer.
- ▶ Before working with the housing open, the device must be disconnected from the grid. A suitable measuring device must be used to ensure that electrically charged parts (e.g. capacitors) are completely discharged.
- ▶ With the aid of a clearly legible, understandable warning sign, ensure that the device remains disconnected from the grid until all work has been completed.

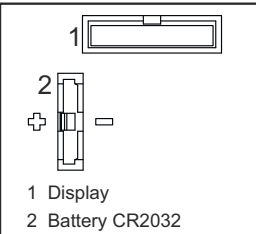
Inside the device:

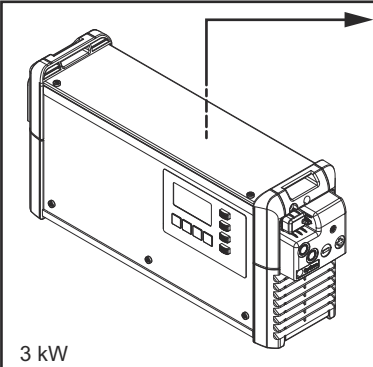
 <p>2 kW</p>	<p>XXXX</p> <p>U<sub>DC</sub> nom. xxV Part No.: 4,010,xxx Ser. No.: xxxxxxxx</p>	 <p><b>WARNING Hazardous Voltage</b></p> <p>Kondensator Entladezeit &lt; 2 min. Capacitor discharge time &lt; 2 min. Décharge de condensateur &lt; 2 min. Condensador tiempo de descarga &lt; 2 min. Condensatore tempo di scaricamento &lt; 2 min.</p>
	 <p>1 Display 2 Battery CR2032</p>	

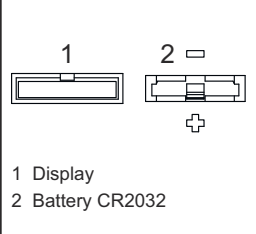
 <p>3 kW</p>	<p>XXXX</p> <p>U<sub>DC</sub> nom. xxV Part No.: 4,010,xxx Ser. No.: xxxxxxxx</p>	 <p><b>WARNING Hazardous Voltage</b></p> <p>Kondensator Entladezeit &lt; 2 min. Capacitor discharge time &lt; 2 min. Décharge de condensateur &lt; 2 min. Condensador tiempo de descarga &lt; 2 min. Condensatore tempo di scaricamento &lt; 2 min.</p>
	 <p>1 Display 2 Battery CR2032</p>	

**Setup regulations**

**⚠ WARNING!**

**Danger from devices falling or toppling over.**

This can result in severe personal injury and damage to property.

- ▶ Set up all system components in a stable position.
- ▶ When using a floor bracket or wall bracket, always ensure that all fastening elements are firmly seated.

The device has been tested according to degree of protection IP21. This means:

- Protection against the penetration of solid foreign bodies with a diameter of more than 12.5 mm (0.49 in.)
- Protection against dripping water falling vertically

The device can be set up and operated in dry, closed rooms in accordance with degree of protection IP21. Avoid exposure to moisture.

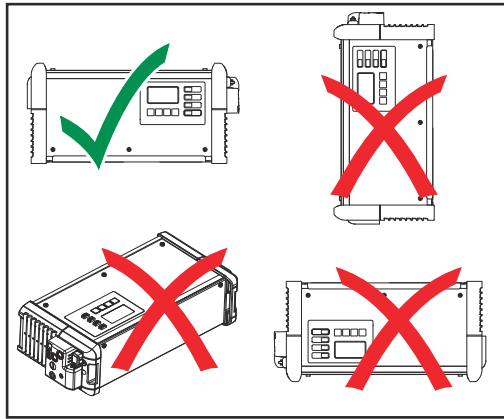

The permissible operating position of the device is horizontal.

The ambient air surrounding the device must be kept free from battery acid vapors as far as possible. Mounting the device directly above the battery to be charged should therefore be avoided.

### Cooling air

The device must be set up so that cooling air can flow through the housing openings provided unhindered. There must always be a minimum distance of 20 cm (7.87 in.) from the air inlet and outlet openings. The ambient air must be free from

- Excessive dust exposure
- Electrically conductive particles (carbon black or metal chips)
- Heat sources

The cooling air flows in and out as indicated by the arrow symbols in the following illustrations.

### NOTE!

#### Danger due to partially or completely covered air intake and outlet openings.

This can result in damage to property.

- The setup of several devices one behind the other should be staggered.

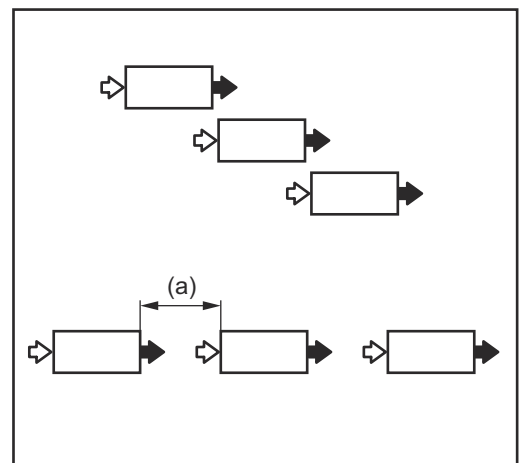
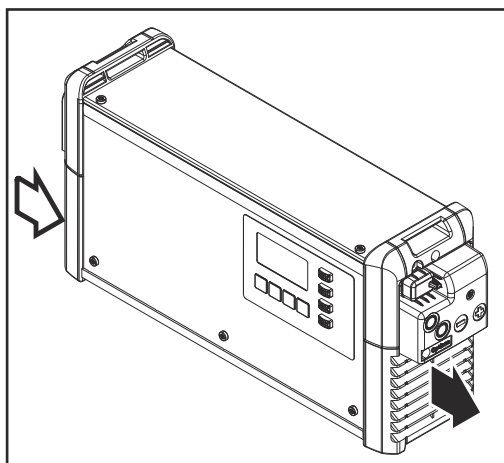

If the devices are arranged in a line one behind the other without being staggered, the distance between the devices must be as follows:

- a) Minimum distance 20 cm (7.87 in.)



Wall and floor mounting

**⚠ WARNING!**

**Danger from incorrectly performed work and falling equipment.**

This can result in severe personal injury and damage to property.

- ▶ The mounting must only be carried out by trained and qualified personnel.
- ▶ Follow the safety rules in the Operating Instructions of the battery charger.

Depending on the substrate, different dowels and screws are required. Therefore, dowels and screws are not part of the scope of supply. The system installer is responsible for selecting the proper dowels and screws.

**⚠ WARNING!**

**Danger from objects falling or toppling over.**

This can result in severe personal injury and damage to property.

- ▶ Check that all screw connections are tightly fastened.
- ▶ Only use with the battery charger provided by the manufacturer.
- ▶ Mount the device horizontally.
- ▶ For wall mounting, the load bearing capacity of the wall must be sufficient.

**Weight of the wall bracket:**

2 kW (B1)	1.10 kg (2.43 lbs.)
3 kW (C1)	1.35 kg (2.98 lbs.)

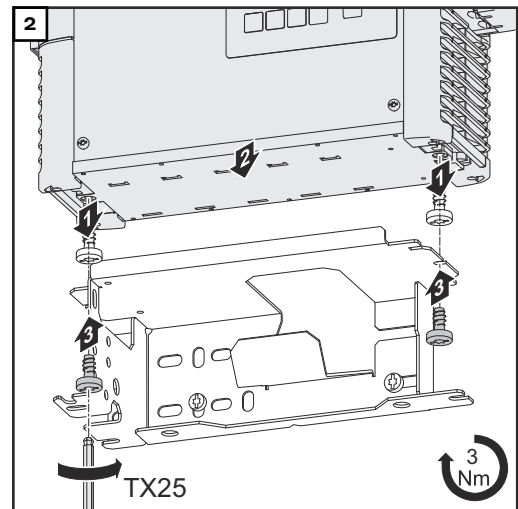
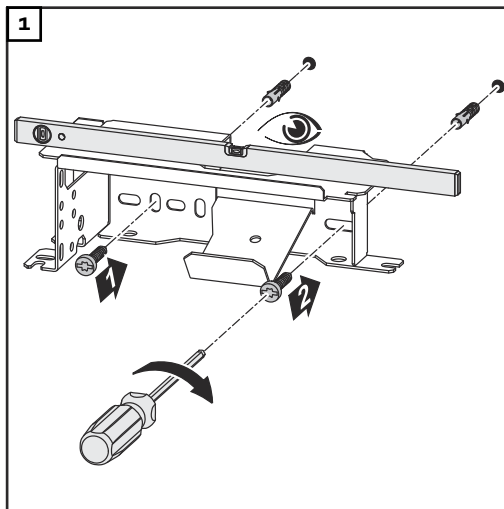

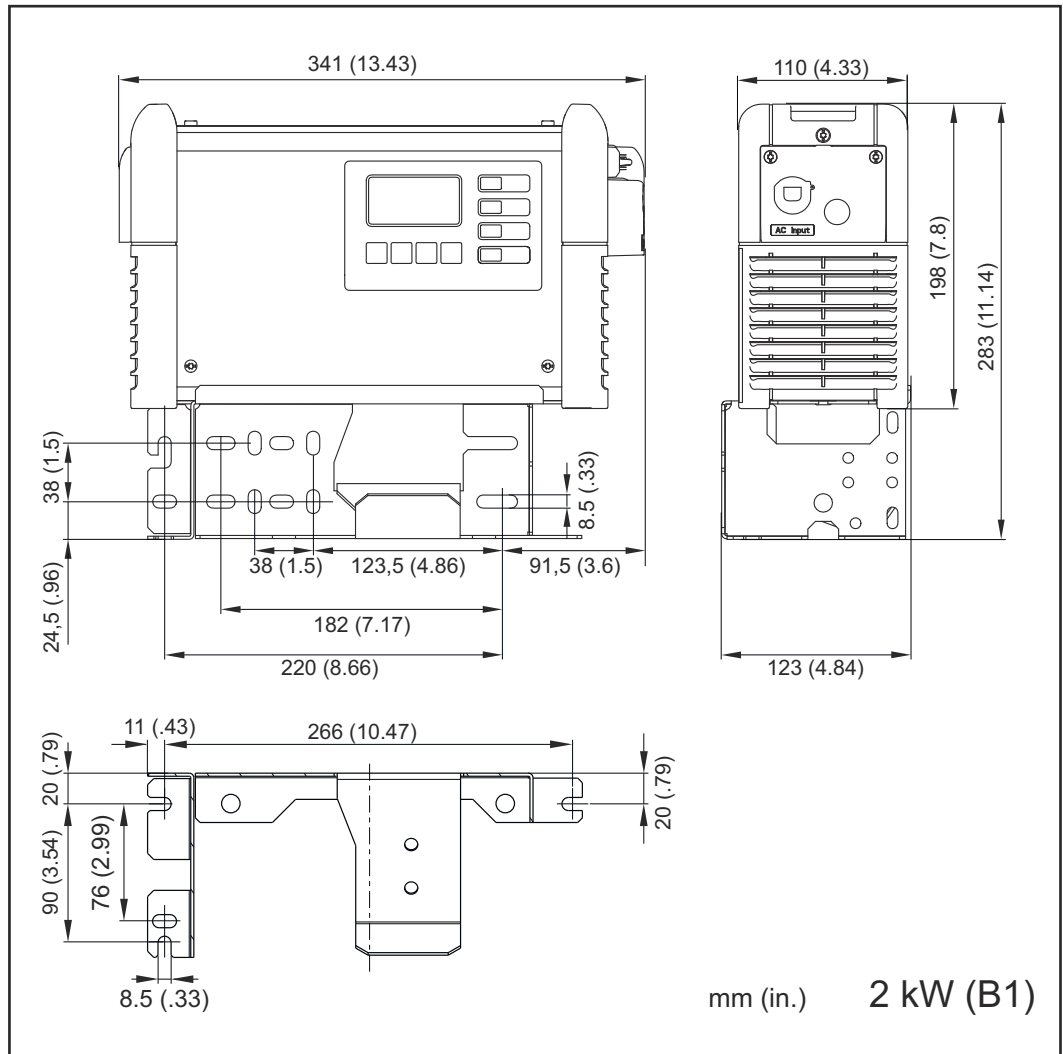

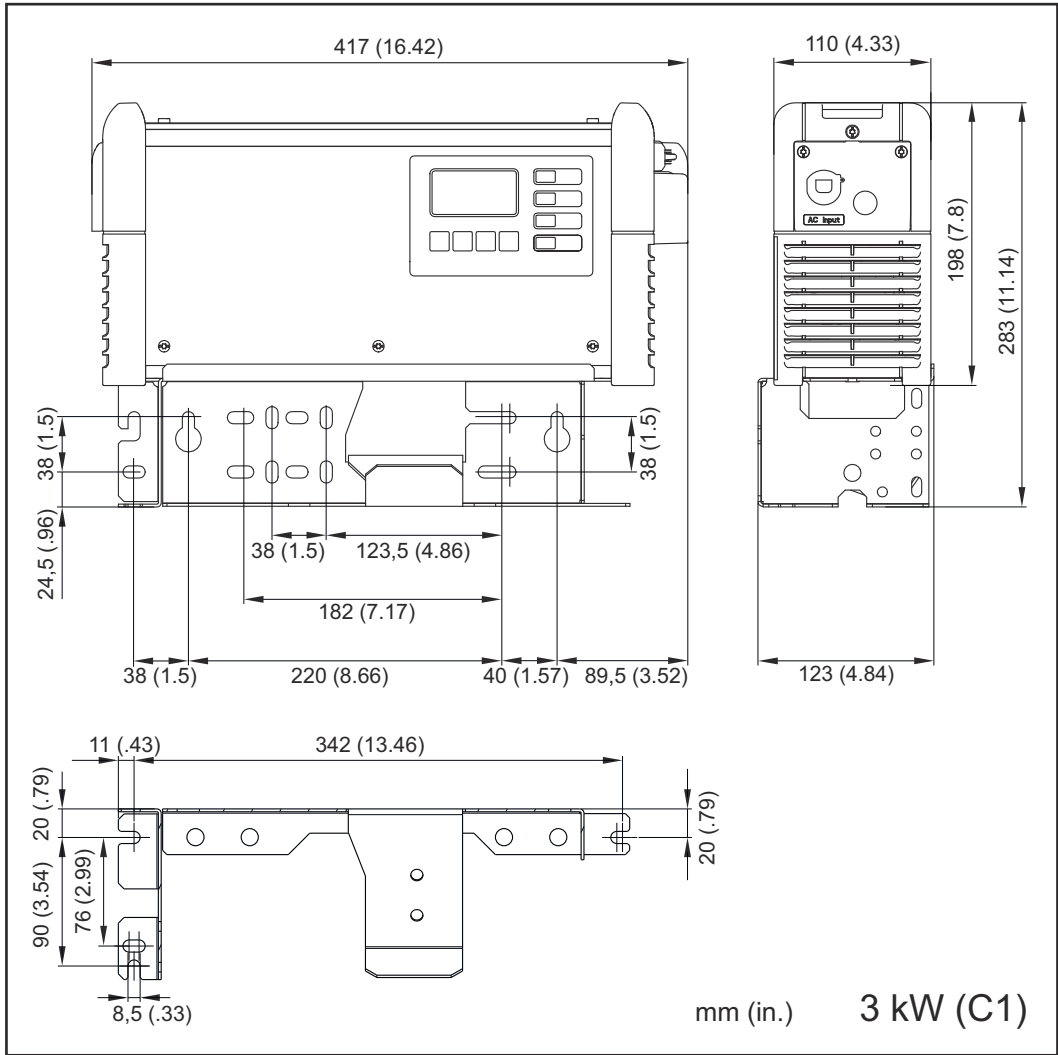

# Operating controls and connections

## Operating controls and connections

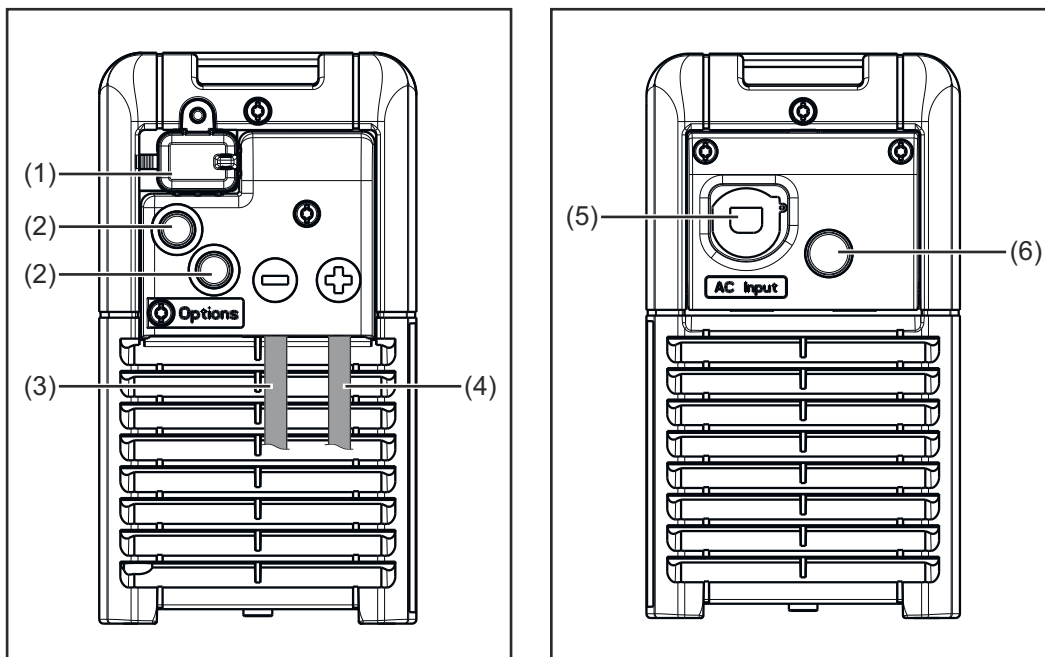

No.	Function
(1)	<b>USB port</b> The USB port supports a device update and the recording of the charging parameters during the charging process via USB thumb drive.
(2)	<b>Position for options</b> - External start/stop option - Temperature-controlled charging option
(3)	<b>(-) Charging cable</b>
(4)	<b>(+) Charging cable</b>
(5)	<b>Mains cable</b>
(6)	<b>Position for the air pump (electrolyte circulation) option</b>

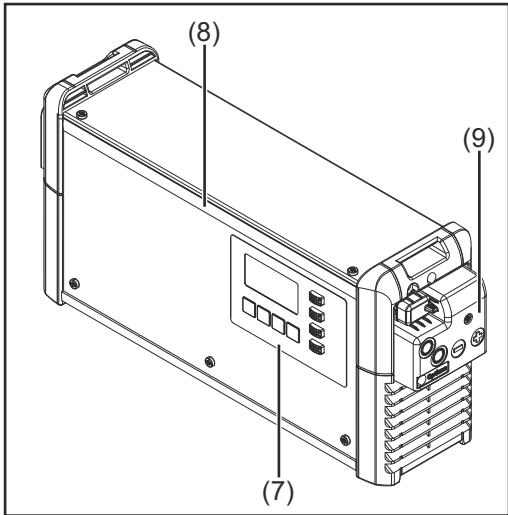

- | No. | Function   |
|-----|--|
| (7) | <b>Control panel</b>   |
| (8) | <b>LED strip option</b><br>Lights up in the appropriate colors depending on the state of charge, according to the indicators explained in the "Control panel" section  |
| (9) | <b>Cover for optional plug and charging cables</b><br>The optional plug and the charging cables are only accessible by removing the cover (9). To do this, follow the warnings in the "Safety" section of the "Options" chapter. |

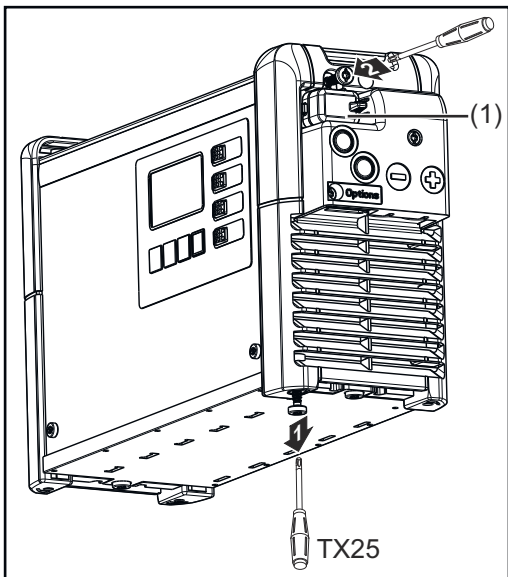







The cover (1) for the USB port can be secured with a screw.

**Pin assignment for 2 kW optional plug**

Pin	Plug Code	Plug 14p	Plug Code	Pin
13	S 1	●	Dete	14
11	S 2	●	C2 G	12
9	C1 G	●	13V O	10
7	C1 L	●	C2 L	8
5	C1 H	●	C2 H	6
3		●		4
1	- St	●	+ St	2

**14-pin optional plug inside the housing**

Pin	Plug Code	Function
13	<b>S 1</b>	
11	<b>S 2</b>	
9	<b>C1 G</b>	<b>CAN 1GND</b> wire brown 
		Remote Control wire 4 Option Box wire brown CBG Easy GND
7	<b>C1 L</b>	<b>CAN 1Low</b> wire yellow 
		Remote Control wire 3 Option Box wire yellow CBG Easy Detect
5	<b>C1 H</b>	<b>CAN 1High</b> wire green 
		Remote Control wire 2 Option Box wire green
3		
1	<b>- St</b>	Temperature Controlled Charging Extern Start / Stop

Pin	Plug Code	Function
14	<b>Dete</b>	<b>Detect</b> wire white 
12	<b>C2 G</b>	<b>CAN 2GND</b> wire brown
10	<b>13 V O</b>	<b>13 V</b> Power Supply wire white 
		Remote Control wire 1 Option Box wire white CBG Easy VCC
8	<b>C2 L</b>	<b>CAN 2Low</b> wire yellow 
6	<b>C2 H</b>	<b>CAN 2High</b> wire green 
4		
2	<b>+ St</b>	Temperature Controlled Charging Extern Start / Stop



Gateway Link



Device for Charge & Connect



TagID Link













Optional for Pb Chargers



### Pin assignment for 3 kW optional plug



Pin	Plug Code	Plug 14p	Plug Code	Pin
13	<b>S 1</b>	● ●	<b>Dete</b>	14
11	<b>S 2</b>	● ●	<b>C2 G</b>	12
9	<b>C1 G</b>	● ●	<b>13V O</b>	10
7	<b>C1 L</b>	● ●	<b>C2 L</b>	8
5	<b>C1 H</b>	● ●	<b>C2 H</b>	6
3		● ●		4
1	<b>- St</b>	● ●	<b>+ St</b>	2

### 14-pin optional plug inside the housing

Pin	Plug Code	Function
13	<b>S 1</b>	<b>Status 1</b>
11	<b>S 2</b>	<b>Status 2</b>
9	<b>C1 G</b>	<b>CAN 1GND</b> wire brown 
		Remote Control wire 4 Option Box wire brown CBG Easy GND
7	<b>C1 L</b>	<b>CAN 1Low</b> wire yellow 
		Remote Control wire 3 Option Box wire yellow CBG Easy Detect
5	<b>C1 H</b>	<b>CAN 1High</b> wire green 
		Remote Control wire 2 Option Box wire green
3		
1	<b>- St</b>	Temperature Controlled Charging Extern Start / Stop

Pin	Plug Code	Function
14	<b>Dete</b>	<b>Detect</b> wire white 
12	<b>C2 G</b>	<b>CAN 2GND</b> wire brown 
10	<b>13 V O</b>	<b>13 V</b> Power Supply wire white 
		Remote Control wire 1 Option Box wire white CBG Easy VCC Status Air Puls
8	<b>C2 L</b>	<b>CAN 2Low</b> wire yellow  
		Air Puls
6	<b>C2 H</b>	<b>CAN 2High</b> wire green  
4		
2	<b>+ St</b>	Temperature Controlled Charging Extern Start / Stop

-  Gateway Link
-  Battery Link
-  TagID Link

-  Device for Charge & Connect
-  Mandatory for Li-Ion Chargers
-  Optional for Pb Chargers

## Control panel

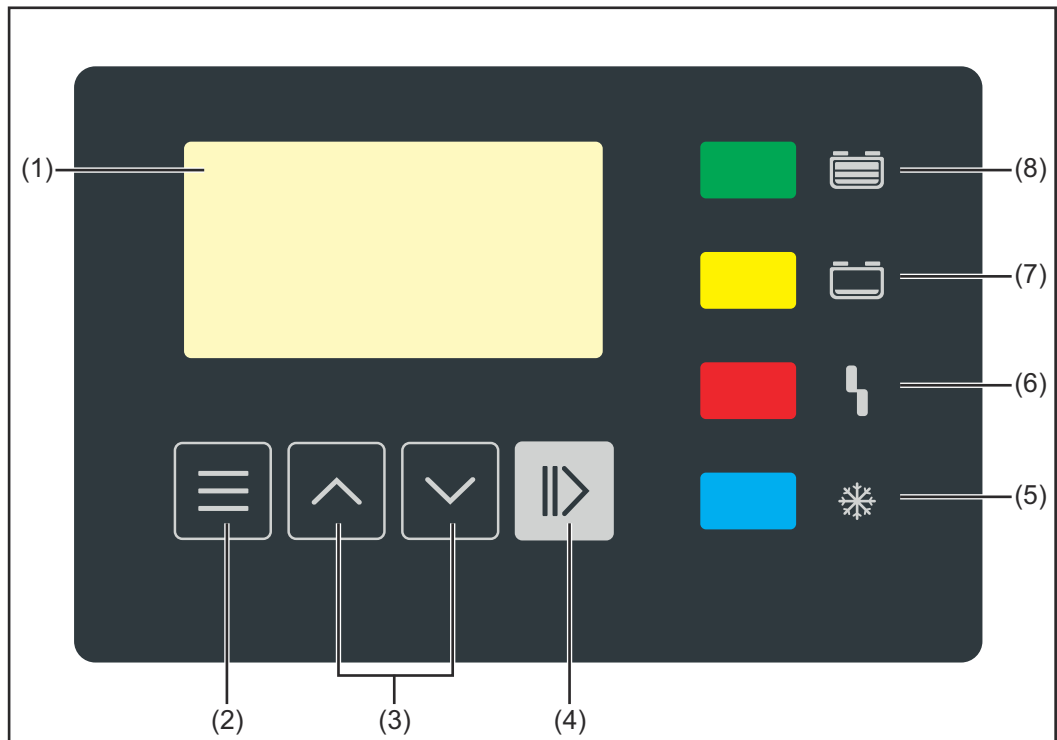

No.	Function
(1)	<b>Display</b> Display of the current charging parameters. Display of settings.
(2)	<b>"Menu" button</b> Select the desired menu. Return to the higher-level selection.
(3)	<b>"Up/Down" buttons</b> Select the desired menu item. Set the desired value.
(4)	<b>"Pause/Start" button</b> Pause and resume the charging process. Confirm a menu item or setting.
(5)	<b>"Battery Cold" indicator (blue)</b> Signals a cooled down battery ready for use. <b>Lights up continuously:</b> At the end of charging, the set cooling time or, optionally, the battery temperature has been reached. <b>Flashes every second:</b> The water refill indicator has also been activated. Detailed information can be found in the <a href="#">Additional functions</a> section of the "Display" chapter.
(6)	<b>"Error" display (red)</b> <b>Lights up continuously:</b> The device outputs an error. The current situation does not allow for proper charging. While the red indicator is lit, charging cannot take place (charging interrupted). The display shows a corresponding status code.



**Flashes briefly every 3s:** The device outputs a warning. Charging parameters are unfavorable, but charging continues. The display alternately shows the corresponding status code and the state of charge.

---

**(7) "Charge" indicator (yellow)**

**Lights up:** during charging.

**Flashes:** when the charge has been interrupted.

---

**(8) "Battery is charged" indicator (green)**

**Lights up continuously:** Charge complete.

**Flashes every second:** Charge complete. The water refill indicator has also been activated.

---

# Charging the battery

## Starting for the first time

When the battery charger is connected to the grid for the first time, the device is in SETUP mode.

In this mode, the following basic settings must be made or confirmed:

- Language (English, German, French, ...)
- Date, time and time zone
- Charging cable length and charging cable cross-section
- Type of battery, curve, number of cells and charging time or battery capacity

1 Connect the mains plug of the battery charger to the electrical network.

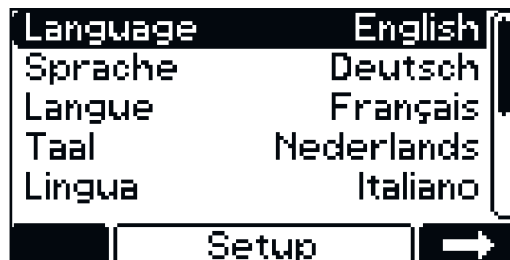

2 Use the "Up/Down" buttons to select the desired menu language.

3 Confirm with the "Pause/Start" button.

English is set as the default language.



4 Use the "Up/Down" buttons to select the time zone.

5 Confirm with the "Pause/Start" button.

The time zone UTC+1 Central European Time (Berlin) is set as default.



The following settings must be made:

- Daylight saving time ON/OFF
- Hour format
- Time
- Date

6 Use the "Up/Down" buttons to select the desired setting.

7 Use the "Pause/Start" button to confirm the respective setting.

Daylight saving time ON and the 24-hour format are set as default.

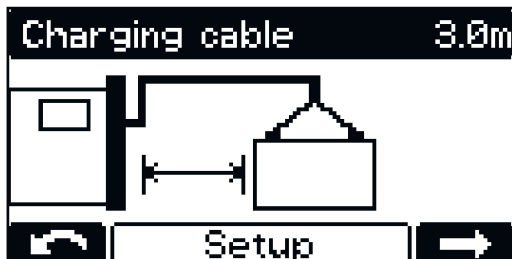

- 8 Use the "Up/Down" buttons to set the appropriate charging cable length.
- 9 Confirm with the "Pause/Start" button.

The battery charger is configured with the correct charging cable length according to the order.

An incorrectly set charging cable length can have a negative effect on the charging process!

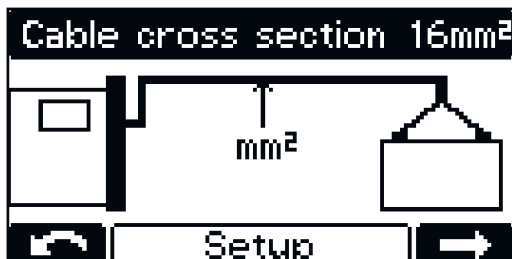

- 10 Use the "Up/Down" buttons to set the appropriate charging cable cross-section.
- 11 Confirm with the "Pause/Start" button.

The battery charger is configured with the correct charging cable cross-section according to the order.

An incorrectly set charging cable cross-section can have a negative effect on the charging process!

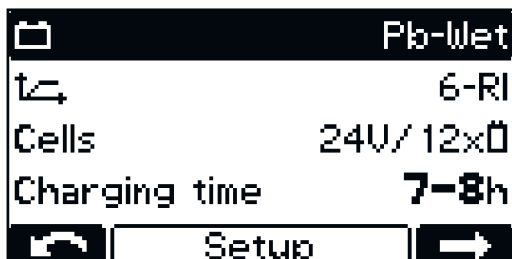

- 12 If the displayed charging configuration is correct, confirm the charging configuration with the "Pause/Start" button.

The battery charger is pre-configured according to the order.

If the battery charger has been ordered without an additional configuration, the following settings are set as default:

- Type of battery Pb-WET (for PzS, GiS)
- Curve 6 - RI
- Maximum number of cells intended for the battery charger
- Charging time 7-8 h

If the configuration does not match the battery used, the parameters must be adjusted accordingly.

Detailed information on the battery charger parameters can be found in the "Configuration mode" section of the "Display" chapter.

**Charging process**

**⚠ WARNING!**

**Danger from leaking battery acid or explosion when charging defective batteries.**

This can result in severe personal injury and damage to property.

- ▶ Before starting the charging process, make sure that the battery to be charged is fully functional.



## WARNING!

### Danger due to incorrect type of battery and incorrect charging settings.

This can result in severe personal injury and damage to property.

- ▶ Before starting the charging process, make sure that the correct type of battery is set on the battery charger.
- ▶ The following settings must be made for the individual types of battery before charging:
  - Charging curve
  - Nominal voltage (number of battery cells)
  - Battery capacity (Ah) or charging time (h)

Detailed information on the battery charger parameters can be found in the "Configuration mode" section of the "Display" chapter.

## NOTE!

### Danger of damage to property due to heavy contamination of the charging plug contacts.

Due to the increased contact resistance, overheating and subsequent destruction of the charging plug can occur.

- ▶ Keep the charging plug contacts free of contamination and clean if necessary.

- 1 Connect the mains plug of the battery charger to the electrical network.

A prompt appears, asking whether the correct parameters have been set for the battery to be charged.

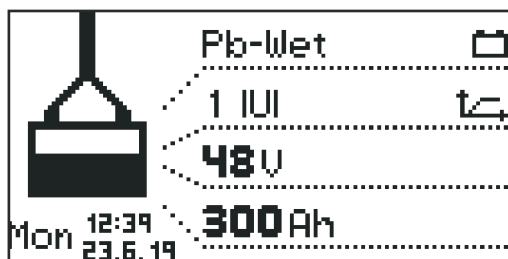

The display then appears in standard mode. The display shows the battery charger parameters:

- Type of battery (e.g., Pb-WET)
- Charging characteristic (e.g., IUI)
- Nominal voltage (e.g., 48 V)
- Capacity (e.g., 300 Ah)
- Weekday, time, and date

The battery charger parameters are individually adjustable. Detailed information on the battery charger parameters can be found in the "Configuration mode" section of the "Display" chapter. Make sure that the battery to be charged corresponds to the battery charger configuration.

- 2 Plug in the charging plug.

The charger detects the connected battery and starts charging. If the start-up delay is activated, the charging process starts after the set delay time has elapsed. Detailed information can be found in the "Configuration mode" section of the "Display" chapter.

During the charging process, the display shows the following values:

- Current charging current (A)
- Current charging voltage (V)
- Charge delivered (Ah)
- Battery temperature with the "Temperature-controlled charging" option
- Time (hh:mm) from start of charge

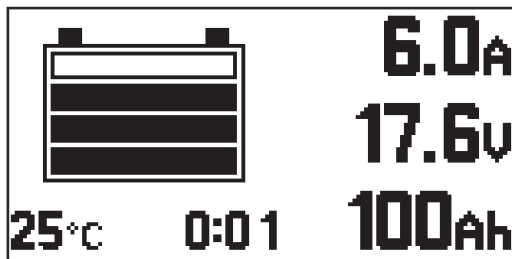

The battery symbol indicates the current state of charge. The more bars are displayed, the further the charging process has progressed. As soon as the battery is fully charged, a minute counter appears (figure on the right). This counts the minutes since the end of charging and makes it easier to judge which battery has cooled down the most when using several battery chargers.

If you still want the standard display to be shown instead of the minute counter:

- 1 Use the "Up/Down" buttons to switch between the minute counter and the standard display.

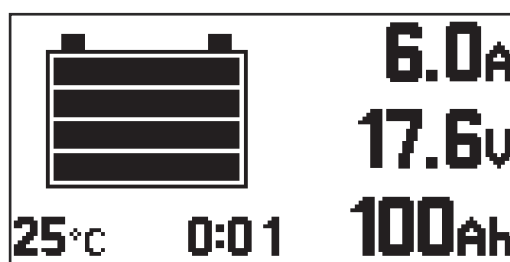
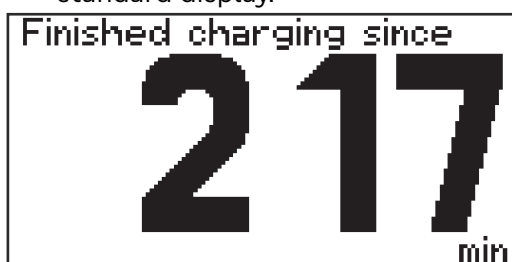

When the battery is fully charged, all 4 bars of the battery symbol appear in black. As soon as the battery is fully charged, the green indicator lights up.

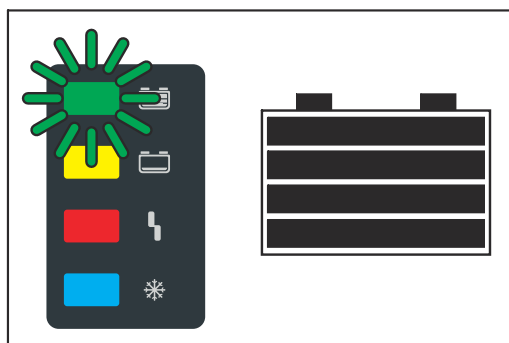

- The battery is always ready for use.
- The battery can remain connected to the battery charger for any amount of time.
- The conservation charge counteracts self discharge of the battery.

**Interrupting the charging process**

Interrupt the charging process as follows:

- 1 Press the "Pause/Start" button.

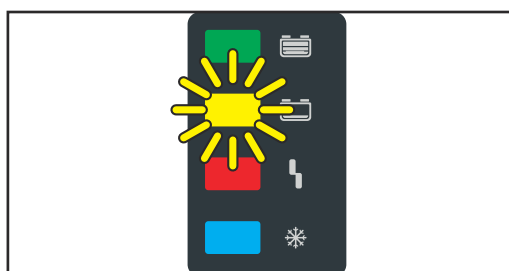

While the charging process is interrupted:

- The "Charge" indicator flashes (yellow).

Resume the charging process as follows:

- 2 Press the "Pause/Start" button again.

As long as a battery is connected to the battery charger, the charging process can only be interrupted and resumed by pressing the "Pause/Start" button. It is only possible to change the display modes with the "Menu" button, as described in the "Display" chapter, after disconnecting the battery from the battery charger.

## Ending the charging process

### **WARNING!**

#### **Danger due to oxyhydrogen ignition caused by sparks when disconnecting the charging cables.**

This can result in severe personal injury and damage to property.

- ▶ Before disconnecting or unplugging the charging plug, end the charging process by pressing the "Pause/Start" button.

### **WARNING!**

#### **Danger if the plug connection is disconnected during the charging process**

This can result in severe personal injury and damage to property.

- ▶ Do not disconnect the plug connection while the charging process is running.
- ▶ Do not touch live contacts on the charging plug.

### **NOTE!**

#### **Danger of battery damage when disconnecting the battery from the battery charger if the charging process is not yet fully completed.**

This can result in damage to the battery.

- ▶ Do not disconnect the battery from the battery charger until it is fully charged (green "Battery is charged" indicator lights up).

Once the battery is fully charged and cooled down, the following indicators light up:

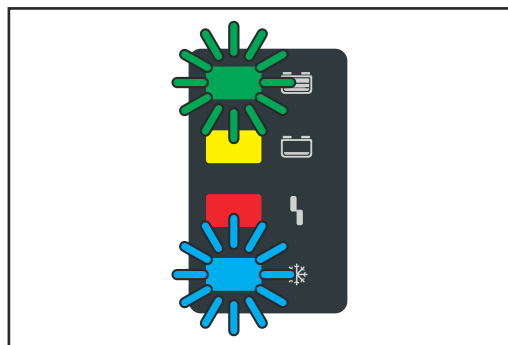

- "Battery is charged" indicator (green)
- "Battery cold" indicator (blue)

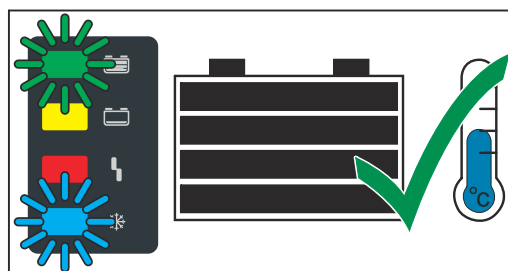

For optimum battery life, do not disconnect the battery from the battery charger until the blue "Battery cold" indicator lights up in addition to the green indicator, as explained below. If several battery chargers are in use, remove the battery that has been fully charged (coolest) for the longest time first.

End the charging process as follows:

- 1 Press the "Pause / Start" key.

2 Disconnect the charging plug.





When the charging contacts are open, the automatic open-circuit detection ensures that the charging contacts are voltage-free.

# Display

---

## Overview of display modes

The device has the following display modes:

No.	Function
	<b>Standard mode</b> In standard mode, the display shows the charging parameters.
	<b>Statistics mode</b> Visualizes the frequency of the operating states of the device and shows the total number of charges, as well as an overview of the absolute and average Ah delivered and energy consumed per charge.
	<b>History mode</b> Provides information regarding the parameters of all stored charging processes.
	<b>Configuration mode</b> Configuration mode enables all settings to be made for the device and the charging process.
	<b>USB mode</b> USB mode supports a device update, the backup and uploading of device configurations, as well as logging of charging parameters during the charging process via USB thumb drive.

As long as a battery is connected to the battery charger, the charging process can only be interrupted and resumed by pressing the "Pause/Start" button. It is only possible to change the display modes with the "Menu" button, as described in the following sections which explain the individual modes, after disconnecting the battery from the battery charger.

While charging has been paused, however, a limited menu selection is available. The display modes described in detail below are available in this case as follows:

Statistics mode and history mode remain unrestricted.

The following data can be called up in configuration mode:

- Date and time
- Device serial number
- Hardware version and serial number
- Software: Main software, secondary software, primary software and curve block version

In USB mode, all functions except "Update" and "Load configuration" can be carried out.

---

## Standard mode

After connecting the mains plug to the electrical network, the display is automatically in standard mode.



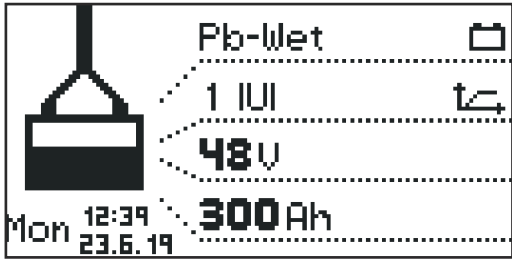

In standard mode, the display shows the battery charger parameters:

- Type of battery (e.g., Pb-WET)
- Charging characteristic (e.g., IUI)
- Nominal voltage (e.g., 48 V)
- Capacity (e.g., 300 Ah)
- Weekday, date and time

The battery charger parameters are individually adjustable. Detailed information can be found in the "Configuration mode" section.

**Menu selection**

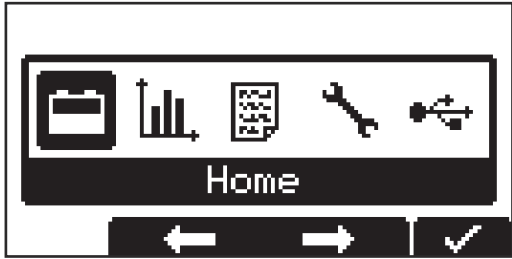

Switch to the menu selection from standard mode as follows:

- 1 Press and hold the "Menu" button for approx. 5 seconds.

Switch to the menu selection from the other modes as follows:

- 1 Press the "Menu" button briefly.

Open the desired mode:

- 2 Use the "Up/Down" buttons to select the symbol for the desired mode.
  - e.g. the battery symbol for standard mode
- 3 Press the "Pause/Start" button to confirm the "check mark" symbol.

**Statistics mode**



In statistics mode, horizontal bars visualize the frequency of the following operating states of the device:

- Idle
- Charging
- Floatingcharge
- Cooldown
- Error

- 1 Use the "Up/Down" buttons to switch between page 1/2 and page 2/2.

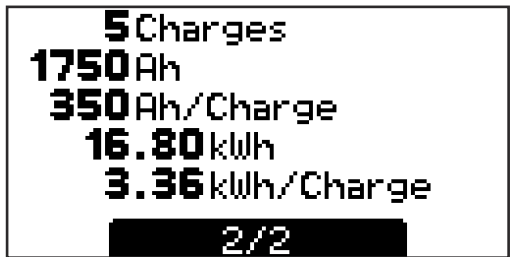

Page 2/2 shows the following values:

- Total number of charges ("Charges").
- Total Ah delivered.
- Average Ah delivered per charge ("Charge").
- Total energy consumed (kWh).
- Average energy consumed (kWh) per charge ("Charge").

The display of the consumed energy is intended as a guide value and may deviate from the actual amount of energy by up to 5% at the rated power. The deviation may be higher at lower power.

## History mode

History mode provides information regarding the parameters of all stored charging processes. The display window is shown twice below in order to be able to show changing or different displays:

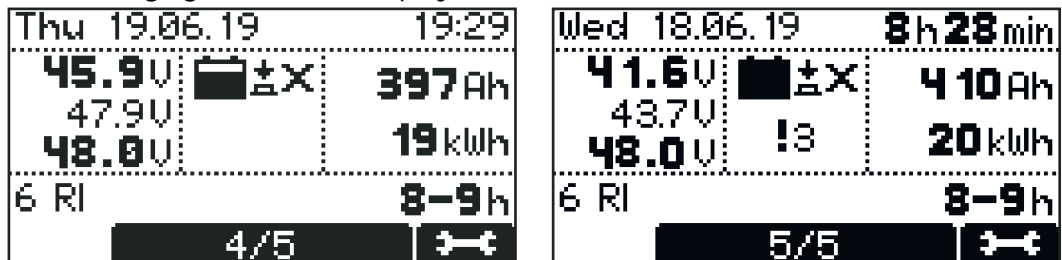

- 1 Use the "Up/Down" buttons to switch between the pages for each saved charging process.

### Contents of the display window

- Start date of the charge, e.g.: Thursday, 19.06.14.
- Start time of the charge, e.g.: 19:29 or charging period, e.g.: 8 h 28 min.
- Voltage when charging starts: e.g.: 45.9 V.
- Voltage after 5 minutes: e.g.: 47.9 V.
- Voltage at end of charge: e.g.: 48.0 V.
- Consumed Ah, e.g.: 397 Ah
- Consumed kWh, e.g.: 19 kWh.
- Charging characteristic, e.g.: 6 RI.
- Set charging period, e.g.: 8 - 9 h or set Ah, e.g.: 400 Ah or set time of end of charge (not shown).

### Displayed symbols

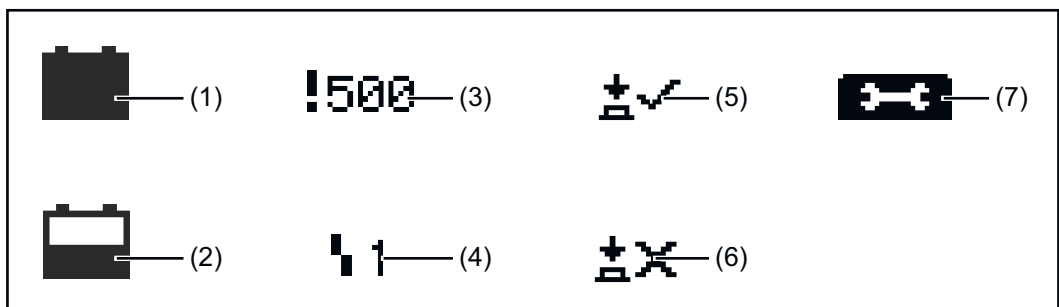

No.	Function
(1)	<b>Full battery</b> Charge completed.
(2)	<b>Empty battery</b> Charge not completed.
(3)	<b>Exclamation mark with number</b> Warning issued, with code for the corresponding status code. Detailed information can be found in the "Status codes" section.

- 
- (4) **Symbol with number**  
Error issued, with code for the corresponding status code. Detailed information can be found in the "Status codes" section.
- 
- (5) **Button symbol with check mark**  
Charge was correctly ended with the "Pause/Start" button.
- 
- (6) **Button symbol with cross**  
Charge was ended without pressing the "Pause/Start" button.
- 
- (7) **Charge details**  
Display of certain battery data at the beginning and at the end of the charge:  
Number of cells  
Ah  
Curve  
Type of battery
- 

## Configuration mode

Configuration mode offers the following setting options:

### Charging settings: Settings for the battery

- Battery type, e.g., "Wet".
- Charging characteristic, e.g., "IU".
- Capacity (Ah) or charging time (h), depending on the charging characteristic.
- Cells: Voltage (V) and number of battery cells or automatic setting of the number of cells.

### CAUTION!

#### **Risk of damage to the battery.**

Damage to the battery may result.

- ▶ Only use the automatic setting of the number of cells for batteries with the following nominal voltage values: 12 V and 24 V for 24 V devices, 24 V and 48 V for 48 V devices.
- ▶ Do not use the automatic setting of the number of cells on deeply discharged batteries.

- 
- Further settings:  
For individual adjustment of the charging characteristic.

### **Additional functions: Zusatzfunktionen**

- Blue LED
- External start/stop
- Refill indicator
- Option Section
- At mains failure restart charging

### General options:

- Language
- Contrast
- Time (hh:mm:ss)  
Time zone  
Daylight saving time/standard time
- Date (dd:mm:yy)
- Charging cable length (m)
- Charging cable cross-section (mm<sup>2</sup>)
- AC current consumption
- Unit for temperature values
- Code for entering the configuration menu activated/deactivated.
- Time interval for the parameters logged on the USB thumb drive (s).
- Reset statistics
- Reset history

### Reset Settings

- With confirmation prompt ("OK?") for further confirmation.

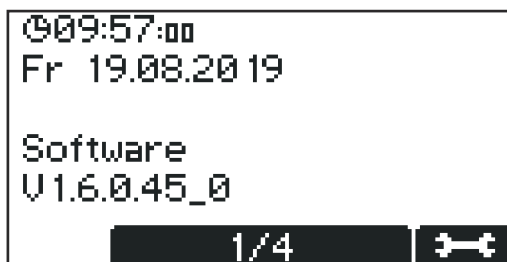

First the screen appears in the basic settings with display of date and time, as well as the software version.

- 1 Use the "Up/Down" buttons to call up the following information:
  - Device serial number as well as serial number and version of the configuration memory.
  - PCB for control/power electronics: Hardware version and serial number.
  - Software: Main software, secondary software, primary software and curve block version.

Enter the configuration menu as follows:

- 1 Press the "Pause/Start" button.



A prompt for the code appears.



Enter the required code "1511" as follows:

- 1 Use the "Up/Down" buttons to enter the first digit of the code.
- 2 Press the "Menu" button to move to the next digit of the code.
- 3 Continue as described above until the complete code is entered.

- Confirm the entry with the "Pause/Start" button.

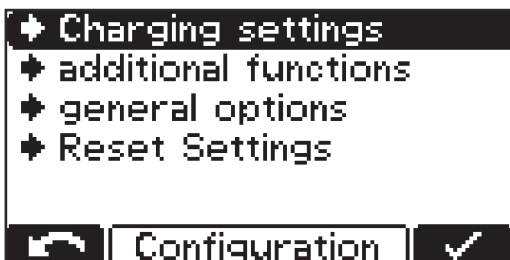

The selection of the main menu items for configuration mode appears.



When selecting a menu item, you may be prompted to read the Operating Instructions. Confirm this prompt by pressing the "Pause/Start" button again.

Navigate through the configuration menu and its submenus as follows:

- Use the "Up/Down" buttons to select the desired menu item.
- Press the "Pause/Start" button to confirm the menu item and confirm any confirmation prompts (e.g. "OK?") again.
- If necessary, use the "Up/Down" buttons to make a selection, e.g. "Off/On" or enter a value.
- Press the "Pause/Start" button to confirm the entry.
- If the cursor moves to the next setting or digit after confirming, proceed again as described in points (3) and (4).

To exit the current menu:

- Press the "Menu" button to return to the higher-level selection.

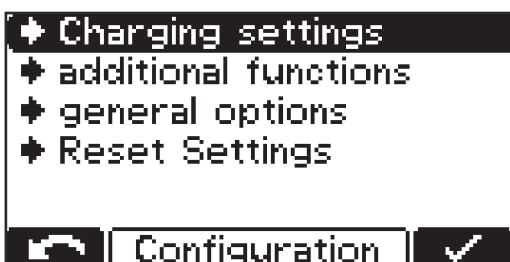

The charge settings are explained below by way of an example:

- Use the "Up/Down" buttons to select the "Charging settings" menu item.
- Press the "Pause/Start" button to confirm the menu item.

The selection of settings for the "Charging settings" menu item appears:

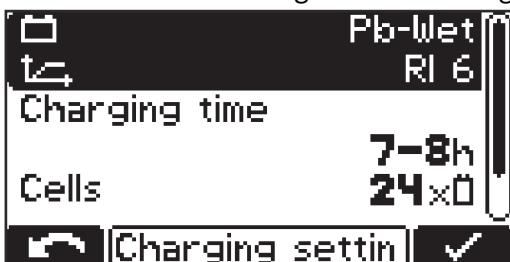

The display may vary depending on the selection made. If "Pb-WET" has been selected as the type of battery as shown in the illustration - in conjunction with the

"RI" curve - the "Ah" section is replaced by a setting option for the "Charging time".

Both the start and end can be set for the charging time. If required, the start time can be deselected; then the charging time is based exclusively on the specified end of charge following a manual charge start.

While making the settings, the user is guided through the menu in the same way as a wizard function.

- 3 Use the "Up/Down" buttons to select the desired parameter (e.g. "Cells").
- 4 Press the "Pause/Start" button to confirm the parameter.
- 5 Use the "Up/Down" buttons to set the desired value (e.g. "24" for the number of battery cells).
- 6 Press the "Pause/Start" button to confirm the entry.

If one or more relevant settings for the charging process are changed in configuration mode, another prompt appears when exiting configuration mode, asking whether the setting in question should be applied.

The following settings must be confirmed when exiting configuration mode:

- Curve
- Battery capacity in Ah (RI curve excluded)
- Number of cells
- Equalizing charge ON/OFF
- CAN protocol

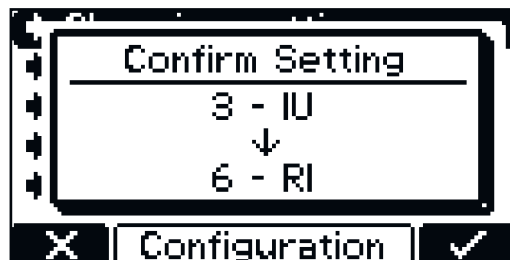

**Example:**

Change to the curve from 3 - IUI (Pb-WET) to 6 - RI (Pb-WET).

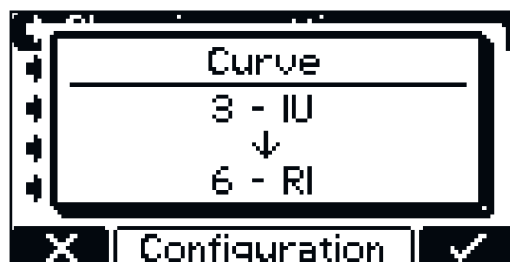

If the setting is not confirmed, the battery charger returns to configuration mode and the setting can be changed to the desired value.

---

## Settings

Below is a detailed explanation of the "Settings" menu item, selected under the aforementioned "Charging settings" menu item. Navigation is carried out as described in the "Configuration mode" section.

A list appears with the following selection options:

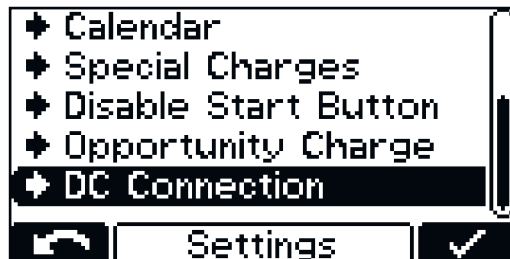
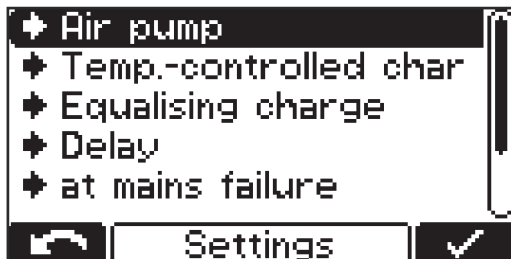

The individual selection options are explained in detail below.

**Electrolyte circulation**

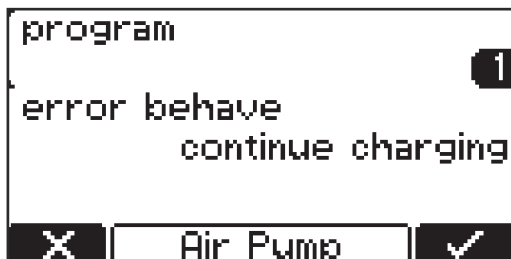

Electrolyte circulation "Air Pump"(not available with the Selectiva 220 V version):

The sequential control of the electrolyte circulation takes place via the battery charger control unit. Several selection options are available for this purpose.

The following settings are available for the electrolyte circulation:

**Off**

- Electrolyte circulation switched off.

**Continuous**

- Electrolyte circulation constantly switched on.

**Program 1 to 5**

- Factory-set programs for the electrolyte circulation and their relevant parameters can be found in the table in the "Settings" section of the "Display" chapter.

**Automatic**

- Automatic adjustment of the flow rate of the electrolyte circulation based on the set battery parameters.

**User "On"/"Off"**

- Individual setting for the electrolyte circulation.
- The "On" and "Off" settings determine the pulse/pause ratio of the airflow intervals.

Factory-set programs for the electrolyte circulation and the relevant parameters are shown in the table below:

Program	ON 1	OFF 1	Repeat	ON 2	OFF 2
1	30 min	25 min	1 x	5 min	25 min
2	3 min	10 min	4 x	3 min	20 min
3	3 min	12 min	1 x	3 min	12 min
4	5 min	10 min	3 x	5 min	20 min
5	2,5 min	7,5 min	1 x	2,5 min	7,5 min

In each of these programs, the solenoid valve picks up for an "ON 1" time and drops out for an "OFF 1" time. This process repeats as many times as specified for "Repeat". After this number of repetitions has elapsed, the "ON 2" and "OFF 2" times continue until the end of charging.

## Temperature-controlled charging

Temperature-controlled charging:

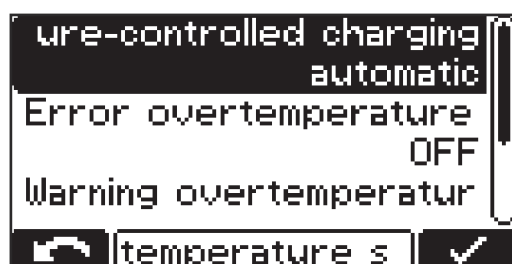

The following settings are available for temperature-controlled charging:

### **automatic/OFF/required**

- automatic ... Temperature-dependent adjustment of the charging characteristic.
- OFF ... The measured battery temperature is not taken into account.
- required ...  
Charging only starts when the temperature sensor is connected.

### **Error overtemperature ON/OFF**

- ON ... An error message is output in the event of a battery overtemperature. The charging process stops and can only be continued after the battery has cooled down and been reconnected.
- OFF ... No error message in the event of a battery overtemperature.

### **Warning overtemperature ON/OFF**

- ON ... A warning is output in the event of a battery overtemperature.
- OFF ... No warning in the event of a battery overtemperature.

For certain curves, an external temperature sensor is required. If such a curve is selected in configuration mode, a message is displayed indicating that an external temperature sensor is required.

### **The following curves require an external temperature sensor:**

- 28 - FCC IUI - CSM WET
- 30 - FCC IUI - WET





If a curve is selected that requires an external temperature sensor, a message appears.

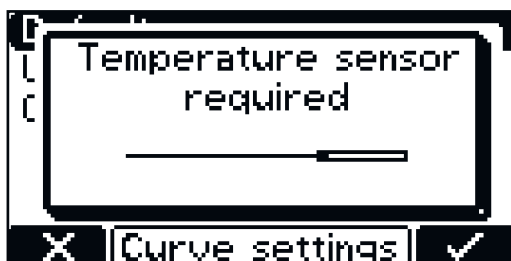

1 Confirm the message by pressing the "Pause/Start" button.

**Equalizing charge**

**Equalising charge**

**OFF**

- No equalizing charge takes place.

**delay**

- If the battery remains connected to the battery charger for the duration of the set equalizing charge delay ("equalize charge delay"), a special form of charging takes place. This prevents acid stratification.
- The parameters for current (amperes/100 ampere hours), voltage (volts/cell) and duration of the equalizing charge can be changed.

**Weekday**

- Specification of the day of the week on which the equalizing charge is to take place.
- The parameters for current (amperes/100 ampere hours), voltage (volts/cell) and duration of the equalizing charge can be changed.

**Manual**

- An equalizing charge can be activated manually by pressing a button on the display.
- The equalizing charge starts after the set delay with the set parameters.
- The parameters for current (amperes/100 ampere hours), voltage (volts/cell) and duration of the equalizing charge can be changed.
- This function is only available for Pb-WET curves.

If a setting for the equalizing charge is activated, a symbol next to the set ampere hours/the set charging time in the home screen indicates whether the equalizing charge is being carried out or can be started.

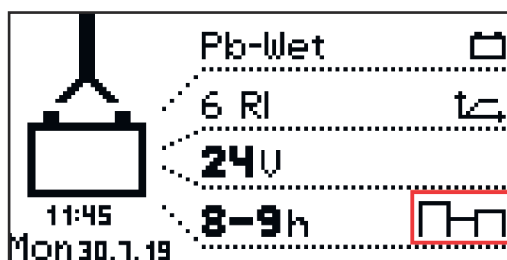

---

## Delay

### delay

#### charge start delay

- Delay time (minutes) between the activation time of the charge start and the actual charge start.

#### charge end delay

- Delay time (minutes) between the signaled end of charge (e.g. green indicator) and the actual end of charge.

#### at mains failure restart charging

- If this option is activated, the charging process is automatically restarted after a fault in the electrical network as soon as the electrical network is available again.

#### at mains failure

- Restart charging
- Automatic/continue charging

If the "Restart charging" option is activated, the charging process is automatically restarted after a fault in the electrical network as soon as the electrical network is available again.

If the "Automatic/continue charging" option is activated, the charging process is automatically continued after a fault in the electrical network as soon as the electrical network is available again.

---

## Calendar

### calendar

The calendar function enables charging to be started automatically according to the following criteria:

- Time window within which charging should not be started when a battery is connected.
- Time window within which a defined curve 1 should be started when a battery is connected.
- Time window within which a defined curve 2 should be started when a battery is connected.

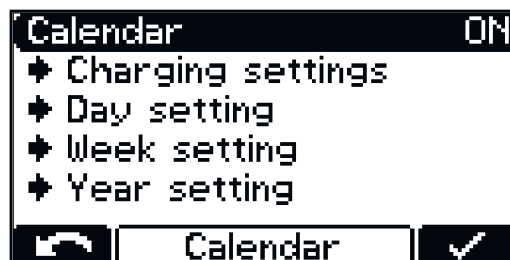

- 1 To activate the calendar function, select and confirm the "ON" setting.



"Charging settings" menu item:

- Type of battery for all curves: e.g. Pb-WET.
- Curve settings when the corresponding curve is selected.

Further settings are possible within the calendar function:

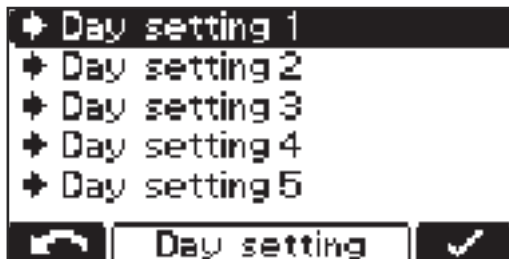

"Day setting 1-5":  
The day settings allow up to 5 different charge start time profiles to be defined, with the following setting options:



- Symbol for curve 1:  
Time window within which curve 1 should be started (e.g.: 0:00-6:00)
- Stop:  
Time window within which no charging should take place (e.g.: 6:00-20:00)
- Symbol for curve 1:  
Time window within which curve 1 should be started (e.g.: 20:00-24:00)

**NOTE!**

**Ongoing charges are not influenced by the set time windows.**

- ▶ If a battery is connected at 05:45 in the above example, charging is stopped when necessary and is not interrupted by the specified end time (6:00 in the example) of the set time window.
- ▶ If the battery is connected within the stop time window, charging will start automatically in the next time window. If a manual charge start is triggered during the stop time window, charging always takes place with curve 1.

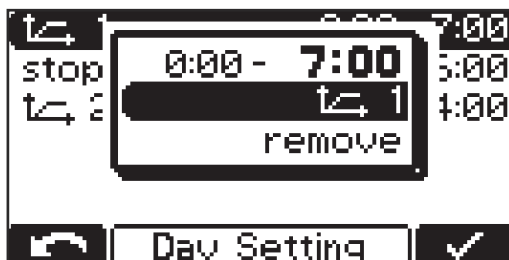

Additional setting options:

- Change the assigned curve: curve symbol.
- Remove the curve in question: "remove".

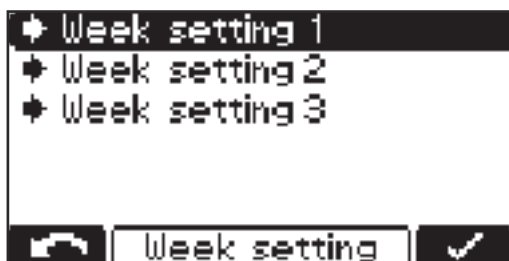

"Week setting":

- It is possible to configure 3 different week settings.

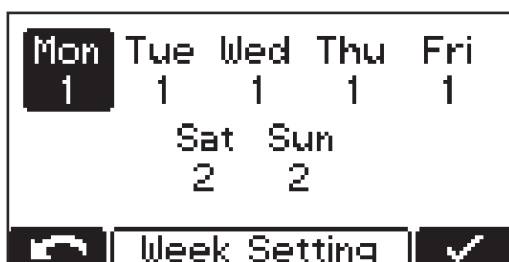

Each day of the week can be assigned one of the previously created day settings.

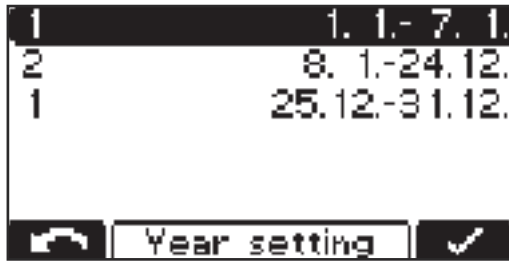

"Year setting":

- It is possible to assign a week setting to several calendar periods (e.g. 1.1. - 7.1.).

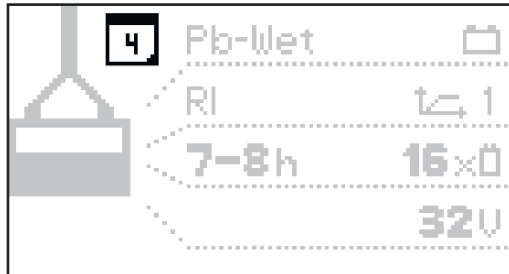

When the calendar function is activated, a calendar symbol (here with the number "4" as the current date) appears in the display.

## Special charges

### Special Charges

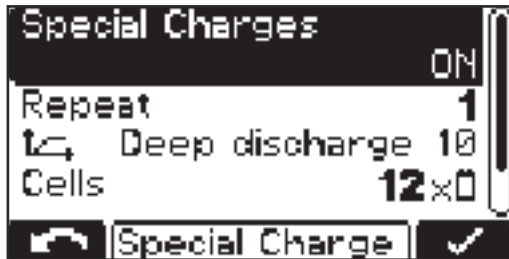

The "Special Charges" selection allows you to temporarily carry out one or more charges that differ from the usual type of charge.

The "Repeat" setting defines how often the special charge is to be carried out until charging is permanently resumed with the original charge parameters:

#### Setting range

- 1 to 99 repetitions

#### Disable Start Button

##### ON

- It is not possible to start the charging process using the "Pause/Start" button, which prevents unauthorized access, for example.

##### OFF

- It is possible to start the charging process using the "Pause/Start" button.

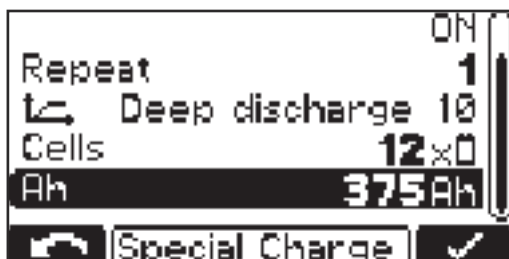

The following settings are also possible:

- Curve:  
e.g. "Deep discharge 10"
- "Cells" - e.g. 12x
- Battery capacity in Ah:  
e.g. 375 Ah

**Special function - opportunity charging**

Special function - Opportunity Charge



In order to extend the operating interval of the battery, it is possible, for example, to recharge the battery during a break in operation.



The following curve settings are possible:

- "Curve" - e.g. RI - Pb-WET
- "Charging time" - e.g. 5-6 h

With opportunity charge set to "ON" and the battery connected, the following display appears:



Display when RI curve is selected



Display for other curves (e.g. IUI)

Start opportunity charge:

- Select the "Runner symbol" (1) with the "Up" button.

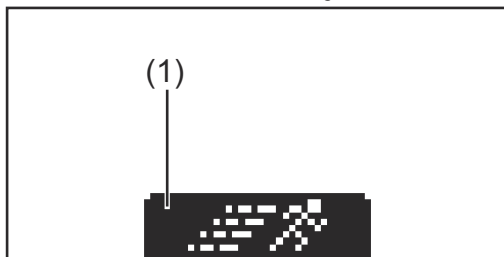

Runner symbol (1)



Display at start of opportunity charge

**DC connection**

DC-Connection:



The Check DC-Connection setting is located in the DC Connection menu. If Check DC-connection is switched on ("ON"), the connection between the battery charger and the battery is checked during the charging process.

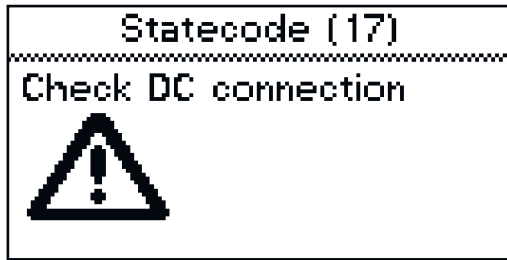

If problems occur with the DC connection during the charging process, status code 17 is set when Check DC-Connection is active. A connection problem can occur, for example, if the charging contacts are worn or dirty.

**Additional functions**

Detailed explanation of the "Additional functions" menu item in configuration mode. Navigation is carried out as described in the "Configuration mode" section.

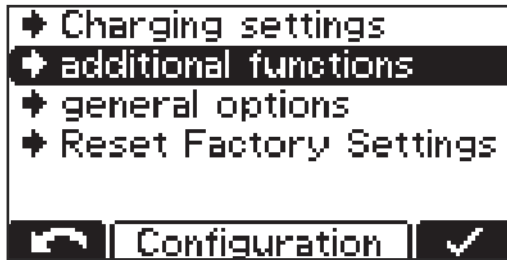

1 Select the "Additional functions" menu item.

A list appears with the following selection options:

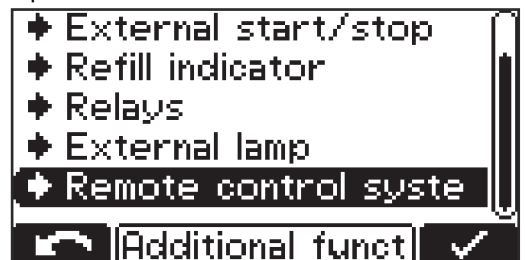
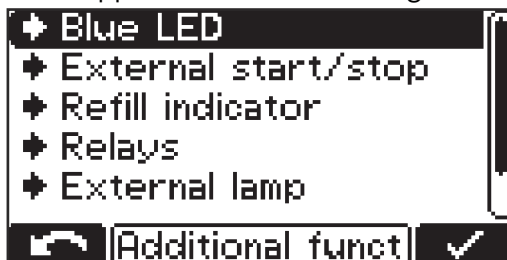

The individual selection options are explained in detail below:

**Blue LED**

Setting for the time (minutes) after which the blue "Battery Cold" indicator should light up to indicate that the battery is sufficiently cooled down. The set value is the time from the end of charging.

In conjunction with the "Temperature-controlled charging" option, it is possible to set a temperature value from which the blue "Battery cold" indicator should light up to indicate that the battery is sufficiently cooled down.

**external start/stop**

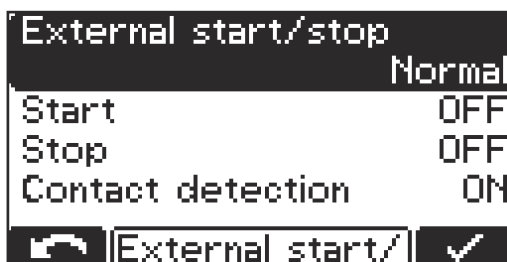

The following settings are available for external start/stop:

**Button**

- The function of the "OK/STOP" button can be simulated by means of an external button.

**Normal**

- **Start ON**  
Charging starts when an external switch is closed and a battery is detected or when the charging plug is plugged in by closing the auxiliary contacts and a battery is detected.
- **Start OFF**  
Charging starts when a battery is connected.
- **Stop ON**  
Charging is interrupted when an external switch is opened or when the charging plug is disconnected by opening the auxiliary contacts.
- **Stop OFF**  
The opening of an external switch or the auxiliary contacts is ignored.

**Contact detection**

- **ON**  
If Start Normal is ON, a battery is connected and the external start/stop contact is not closed, error 16 is set.  
If Stop Normal is ON, charging has been started, the external start/stop contact is opened and the battery is not fully charged, error 16 is set.
- **OFF**  
Contact detection is not executed.

**Refill indicator**

The refill indicator is activated as soon as it is necessary to add distilled water to the battery. The time of the refill request can be defined as follows:

**Every x-th week and weekday**

- e.g. refill water every 2nd week on Friday

When "OFF" is set, the refill request does not have to be confirmed.

**Option Section**

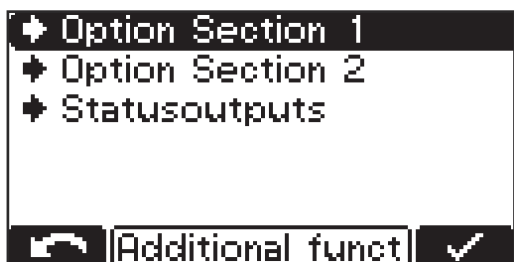

**Option Section 1**

- Setting options:  
CAN1 (option box)  
Cool Bat Guide Easy (Fronius variant only)

**Option Section 2 (3 kW only)**

- Setting options:  
CAN2 (option box)  
Air-Puls (EUW)

**Status outputs (3 kW only)**

- External lamp setting (normal or RGB)

### at mains failure restart charging

If this option is activated, the charging process is automatically restarted after a fault in the electrical network as soon as the electrical network is available again.

## General options

Detailed explanation of the "General options" menu item in configuration mode.

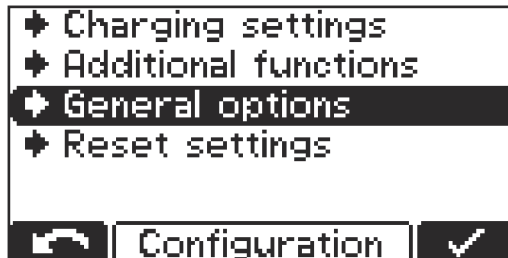

- 1 Select the "General options" menu item.

A list appears with the following selection options:

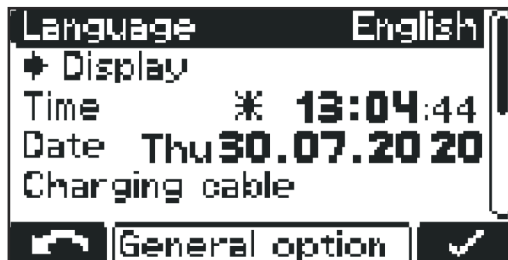

- Language
- Display
  - Contrast
  - LED brightness
  - Show Ah at charge end ON/OFF
- Time and Date
  - Daylight saving time/standard time
  - Predefined time zones
  - User-defined time zones

### Charging cable:

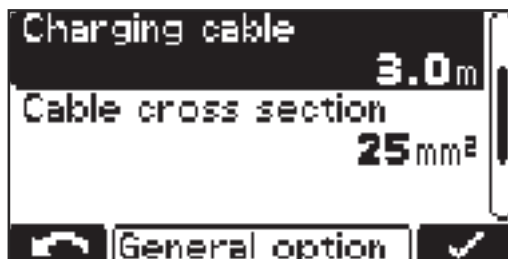

- Simple length of the charging cable (m)

### Cable cross section:

- Cross section of the charging cable (mm<sup>2</sup>)

### AC current consumption:

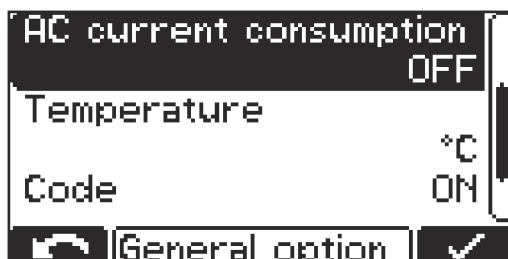

- Adaptation of the maximum device current to the electrical installation on site, or to the device plug which has been installed on the device.





- The minimum and maximum values differ for the different device classes. The minimum value is approx. 25% of the maximum nominal current of the device concerned.

**Temperature:**

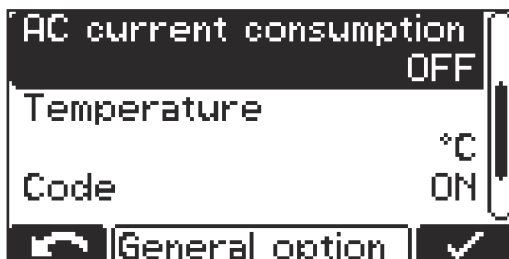

- Temperature in °C/°F

**Code:**

- Code entry required/not required to enter configuration mode ("Code ON/OFF")

**USB Logging Time:**

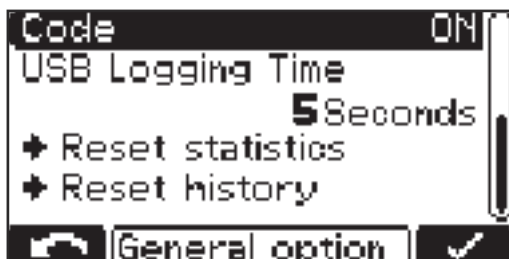

- Time interval for the charging parameters logged on the USB thumb drive (s) ("USB Logging Time")

**Reset statistics**

**Reset history**

Detailed information regarding statistics and history can be found in the "Statistics mode" and "History mode" sections.

**Reset settings**

The menu item below "General options" offers 2 possibilities to reset all settings:

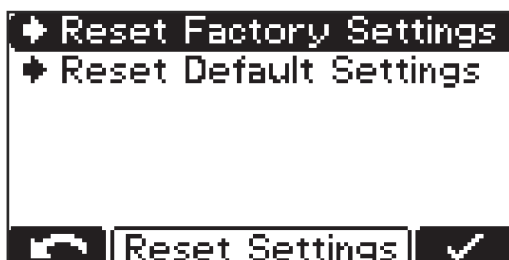

**Reset Factory Settings:**

- Reset the settings made to the factory settings.

**Reset Default Settings:**

- Resetting the settings made to the manufacturer's default settings.

## USB mode

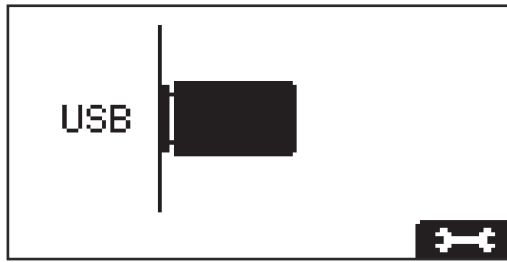

In USB mode, the display shows whether a USB thumb drive is plugged in.

The USB thumb drive must meet the following specifications:

- Formatting: FAT32
- 32 Gigabyte maximum
- No multiple partitioning

The **I-SPoT-VIEWER** software ([www.fronius.com/i-spot](http://www.fronius.com/i-spot)) supports the visualization and evaluation of the data on the USB thumb drive.

Only plug in the USB thumb drive when no charging process is taking place or the charging process has been interrupted.

If the charging process has only been interrupted and not completely ended, it is only possible to read data and not to perform an update or load a configuration.

### Navigating in USB mode

- 1 Press the "Pause/Start" button to change to the settings listed below.
- 2 Use the "Up/Down" buttons to scroll between the settings.
- 3 Press the "Pause/Start" button to confirm the desired setting.

To start a data download, confirm this again with the "Pause/Start" button. If this repeated confirmation with the "Pause/Start" button is not carried out, the download starts automatically after one minute.

While a charging process is in progress, the USB thumb drive may be connected after pressing the "Pause/Start" button. It is only possible to read data and not to perform an update or load a configuration.

### Safely remove

- Safely remove the USB thumb drive once the desired action is complete.

### Update

- A list of suitable update files stored on the USB thumb drive opens.
- The desired file is selected and confirmed in the same way as scrolling through the settings.
- Do not rename the automatically assigned file name of the update file!
- The latest firmware is available in the **download area** of the Fronius website.
- Firmware installation instructions are included in the zip file of the download.

### Download

- The data of the logged charging parameters stored in the data logger of the device is saved for the I-SPoT VIEWER on the USB thumb drive.
- Events as well as device settings and user curves (configuration) are also saved.
- The following time ranges can be selected for the data logger:
  - 1 month
  - 3 months
  - All
  - Since last time

### Download optional

The following options are available:

- I-SPoT VIEWER  
The logged data is saved in the same way as for the "Download", but only with the data for the I-SPoT VIEWER.
- Save data logger  
The logged data is saved in the same way as for the "Download", but as "csv" files rather than in the I-SPoT VIEWER format.  
(Automatically created folder structure for the ".csv" files: \*  
Fronius\<Device serial number>\Charges\<yyyymmdd>\<hhmmss.csv>)
- Save events.  
Events are saved on the USB thumb drive.
- Save configuration.  
The device settings are saved on the USB thumb drive.

### Load configuration

- Loads a suitable device configuration stored on the USB thumb drive into the device.

### Load dealer text

- Here a text file can be loaded from the USB thumb drive, which is displayed as soon as the device is in an error state.
- The text file can contain the contact details of the dealer, for example.
- The file must be saved on the USB thumb drive in the ".txt" format in "uni-code".
- The file name must be "dealer.txt".
- The number of characters is limited to 99.

- \* If a USB thumb drive is plugged in during charging, the csv files are saved directly on the USB thumb drive. The folder structure, which is also created automatically, contains the "Datalog" folder instead of the "Charges" folder.

### Status codes

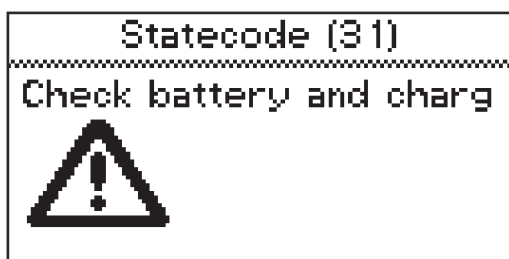

If a fault occurs during operation, specific status codes may be displayed. This can be caused by the following:

- Battery error
- A battery with an unsuitable voltage has been connected.
- The device has overheated.
- A software or hardware error has occurred.

Battery error:

If the battery reports an error state, the battery charger will display this error as a battery error including the corresponding error number of the battery. The respective error explanation can be found in the Operating Instructions for the battery.

If an error message appears on the display and the error cannot be rectified independently:

- 1** Note down the displayed status code: e.g., "Statecode (31)".
- 2** Note the configuration of the device.
- 3** Contact your authorized Service Partner.  
If the device is in an error state, a freely defined text can be displayed, which can contain the contact details of the distributor, for example.

#### **Status codes with an external cause**

<b>No.</b>	<b>Cause / Remedy</b>
(11)	Check mains voltage
(12)	Check grid (phase failure)
(13)	External temperature sensor defective
(14)	Electrolyte circulation defective (pressure switch does not switch)
(15)	No control voltage detected
(16)	External start/stop is not closed.
(17)	Open circuit detection triggered several times during a charge (e.g.: worn charging contacts)

#### **Status codes in the event of a battery fault**

<b>No.</b>	<b>Cause / Remedy</b>
(22)	Battery undervoltage
(23)	Battery overvoltage
(24)	Battery too hot (only with external temperature sensor)
(25)	Battery undertemperature (only with external temperature sensor)
(26)	Cell defect detected
(27)	Battery not supported
(28)	Battery heavily discharged - safety charge in progress
(29)	Incorrect battery polarity
(30)	Thermal Runaway

#### **Status codes in the event of a CAN error (battery)**

<b>No.</b>	<b>Cause / Remedy</b>
(51)	Battery not responding
(52)	Battery data cannot be queried
(53)	Battery voltage not supported
(54)	Communication error
(55)	Battery error
(56)	Battery does not switch on

---

(57) Message time limit exceeded

---

(58) Login failed

---

#### **Status codes in the event of a gateway error**

<b>No.</b>	<b>Cause / Remedy</b>
------------	-----------------------

(101)	CAN Connect setting is active and no CAN connection could be established to the gateway for at least 2 minutes.
-------	---

(102)	Gateway has no connection to the back-end.
-------	--

#### **Status codes in the event of a charging error**

<b>No.</b>	<b>Cause / Remedy</b>
------------	-----------------------

(31)	Time exceeded in the I1 phase
------	-------------------------------

(32)	Time exceeded in the U1 phase
------	-------------------------------

(33)	Battery overvoltage in the I2 phase
------	-------------------------------------

(34)	Ah exceeded
------	-------------

(35)	Time exceeded in the I2 phase
------	-------------------------------

(36)	Target voltage in the I2 phase not reached (only with format characteristic)
------	--

(37)	RI charge error
------	-----------------

(38)	Set charging time cannot be reached
------	-------------------------------------

(39)	Time exceeded during RI charge
------	--------------------------------

#### **Status codes in the event of an error in the primary circuit**

<b>No.</b>	<b>Cause / Remedy</b>
------------	-----------------------

(500)	Temperature sensor module 1 (top) defective
-------	---

(501)	Temperature sensor module 2 (bottom) defective
-------	--

(502)	Temperature sensor PCB defective
-------	----------------------------------

(503)	Primary overtemperature
-------	-------------------------

(504)	Fan blocked / defective
-------	-------------------------

(505)	Over-/undervoltage in intermediate circuit
-------	--

(506)	Asymmetry in intermediate circuit
-------	-----------------------------------

(507)	Primary supply voltage out of tolerance
-------	---

(508)	Grid failure
-------	--------------

(509)	Incorrect device configuration
-------	--------------------------------

(510)	Primary EEPROM faulty
-------	-----------------------

(527)	Phaseshifter overcurrent
-------	--------------------------

(528)	High charge relay switched off during load operation
(530)	Communication problem
(532)	Microcontroller error (e.g., division by 0)
(533)	Reference voltage out of tolerance
(534)	Startup problem
(535)	PFC overcurrent
(536)	Phaseshifter or PFC faulty

#### **Status codes in the event of an error in the secondary circuit**

<b>No.</b>	<b>Cause / Remedy</b>
(520)	Secondary temperature sensor defective
(521)	Secondary overtemperature
(522)	Output fuse defective
(523)	Secondary supply voltage out of tolerance
(524)	Secondary reference voltage out of tolerance
(525)	Current offset
(526)	Current offset out of tolerance
(527)	Power module overcurrent (primary)
(529)	No secondary communication
(530)	No primary communication
(531)	Secondary EEPROM defective
(532)	Microcontroller error
(537)	Voltage measurement faulty
(570)	Secondary relay cannot be switched
(571)	ADC/SPI problem

#### **Status codes in the event of an error in the control system**

<b>No.</b>	<b>Cause / Remedy</b>
(540)	Configuration memory block missing/defective
(541)	No secondary communication
(542)	Secondary Init failed
(543)	Program/memory error in the characteristic control
(544)	Program/memory error in the characteristic control
(545)	Primary Init failed
(546)	Update failed

---

(547)	Load/save settings failed
(548)	Load/save curve settings failed
(549)	Charge could not be continued after a power failure
(550)	Time not set
(551)	Hardware change detected
(552)	Configuration memory block invalid
(553)	Primary update failed
(554)	Master-slave communication faulty
(555)	Incorrect device software
(557)	Interruption of the InterLock communication
(558)	The second device, which is connected via the InterLock, has an error
(559)	The second device, which is connected via the InterLock option, is incompatible with this device

---

# Options

---

## Safety

In order to connect optional components, it may be necessary to open the housing. Observe the following warnings:

### **WARNING!**

#### **Danger of electric shock.**

This may result in serious injuries or death.

- ▶ The housing must never be opened by anyone other than a service technician trained by the manufacturer.
  - ▶ Before working with the housing open, the device must be disconnected from the grid.
  - ▶ A suitable measuring device must be used to ensure that electrically charged components (e.g., capacitors) are completely discharged.
  - ▶ With the aid of a clearly legible, understandable warning sign, ensure that the device remains disconnected from the grid until all work has been completed.
- 

### **WARNING!**

#### **Danger due to work that is not carried out properly.**

This can result in severe personal injury and damage to property.

- ▶ All work involved with connecting optional components must only be carried out by qualified specialist technicians.
  - ▶ If there are Installation Instructions or User Information for the optional component concerned, then all warning notices and instructions therein must be obeyed.
  - ▶ For all options with electrical connections, a safety inspection must be carried out in accordance with the applicable national and international standards and guidelines after connection work has been carried out.
  - ▶ You can obtain more information about the safety inspection from your authorized Service Partner.
  - ▶ The Service Partner will provide the necessary documents upon request.
- 

### **WARNING!**

#### **Danger from devices falling or toppling over.**

This can result in severe personal injury and damage to property.

- ▶ Due to its weight, the device must be secured against falling down and toppling over by means of suitable mounting accessories.
  - ▶ The wall and floor brackets offered by the manufacturer must be used.
- 

## 3 kW electrolyte circulation

### **NOTE!**

#### **Danger due to electrolyte penetrating from the battery or due to operation without backpressure.**

Damage to the air pump may result.

- ▶ Always position the battery charger so that it is at least 0.5 m (1 ft. 7.69 in.) above the battery to be charged.
  - ▶ Always connect the compressed air output on the battery charger to the battery via the hose connection provided, ensuring it is in perfect condition.
-



**NOTE!**

**Danger due to non-compliance with the permissible mains voltage tolerance.** Malfunctions and damage to property may result.

- For the electrolyte circulation option, a limited mains voltage tolerance of 207 V to 250 V applies compared to the battery charger.

The electrolyte circulation option delivers air into the battery via specially designed capillary tubes. This results in an intensive mixing of the electrolyte. The benefit is less battery heating, a longer battery life and less water loss during charging.

If an error is detected due to a pump defect - or due to leaks in the connection to the battery - the status code "Statecode 14" appears on the display. This defect can be indicated as a common error by means of an external signal lamp, for example.

**Weight of the electrolyte circulation pump:  
Air-Puls + air hose set**

3 kW

2.5 kg (5.51 lb)

**Air filter insert of the electrolyte circulation pump**

Clean the air filter insert for the integrated air pump once a year. If there is a lot of dust, shorten the cleaning interval accordingly. It is necessary to remove the air filter insert for cleaning purposes. Remove the air filter by levering it out with a slotted screwdriver and then reinstall it as follows:

**NOTE!**

**Danger when using the air filter with battery chargers not designed for this purpose.**

This can result in damage to property.

- Only use the air filter with the battery chargers provided by the manufacturer.

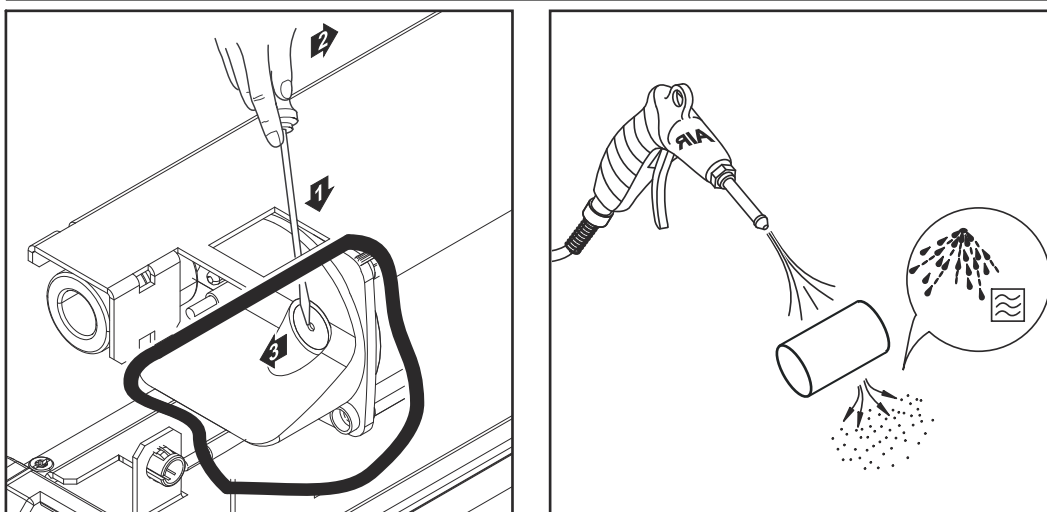

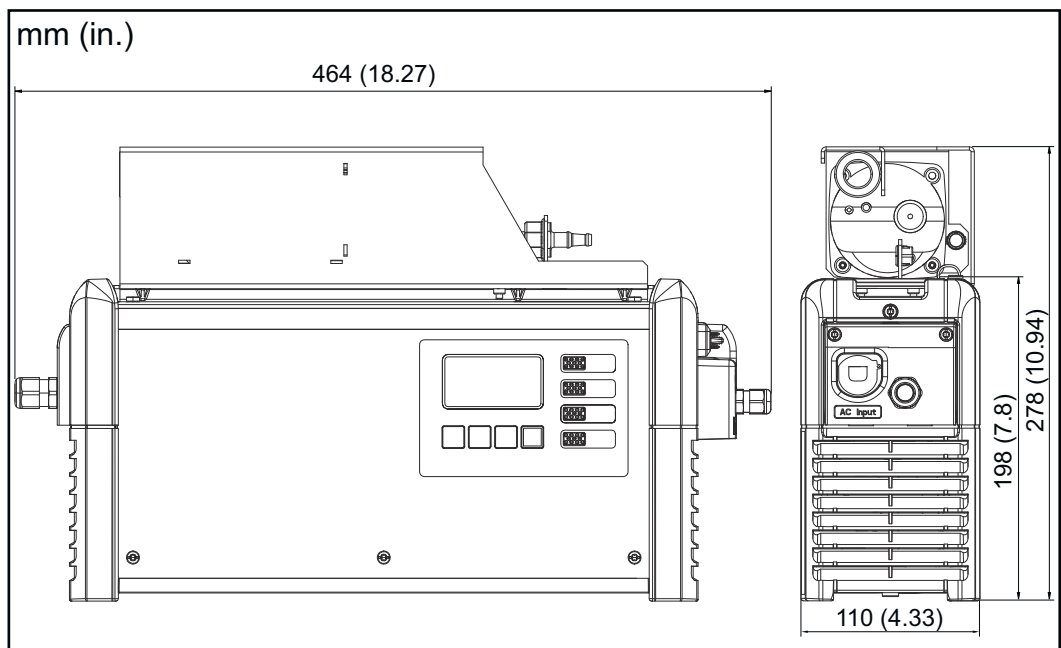
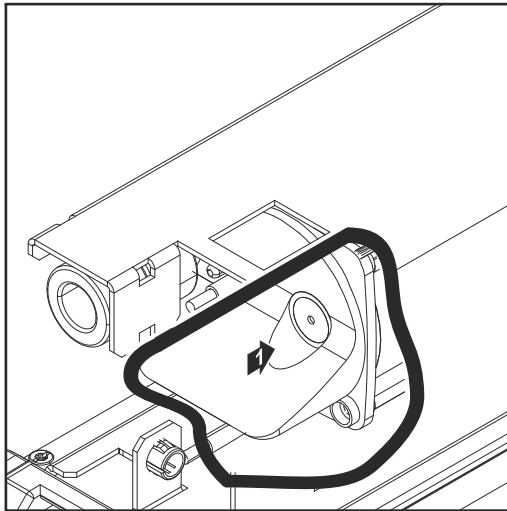

**External start/  
stop**

The external start/stop option prevents spark formation at the charging plug if it is disconnected during charging. Special contacts inside the charging plug register a disconnection from the charging socket. These contacts are leading in comparison to the main contacts. An immediate charging stop is triggered. There is therefore no wear on the main contacts and the level of safety against oxyhydrogen ignition is increased.

**Temperature-  
controlled charging**

The temperature-controlled charging option continuously regulates the charging voltage according to the current battery temperature. This significantly extends the battery-life, especially when used in cold rooms.

**LED strip**

The LED strip serves as a status indicator and lights up in the corresponding colors in the same way as the display elements of the control panel. An LED strip including diffuser is installed in the gap between the front wall of the housing and the upper part of the housing.

**Air filter** In dusty environments, the air filter prevents contamination of the inside of the device. This prevents any reduction in performance or other impairment of the device. Detailed information can be found in the corresponding User Information. Cleaning interval as required (manufacturer's recommendation: monthly)

**Wall and floor bracket** The robust wall and floor bracket with integrated cable holder ensures safe installation at the place of use. Detailed information and illustrations can be found in the "Wall and floor bracket" section of the "General information" chapter.

**"Mobile" set** A carrying strap increases the mobility of the device.

**Option box** With the option box, information regarding the state of charge of the attached battery can be forwarded via an external circuit. Error messages and additional features such as Aquamatic, external air pump and refill indicator can also be output.

**Mounting plate** The mounting plate acts as a space-saving floor or wall bracket.

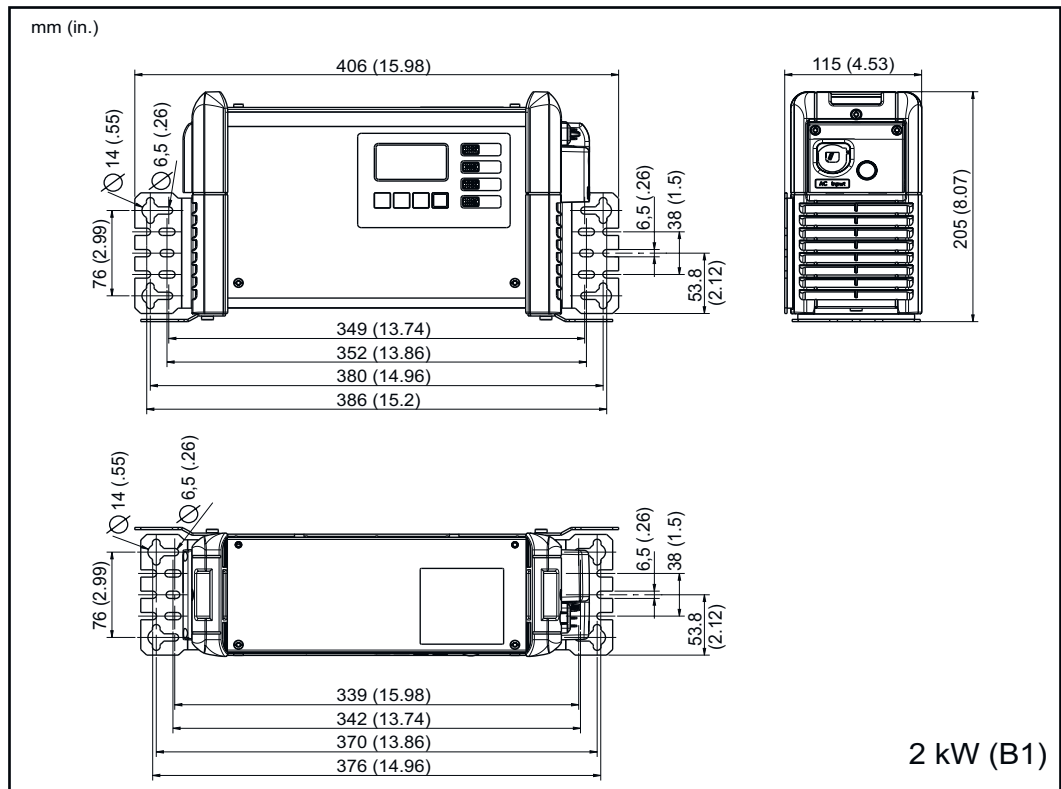

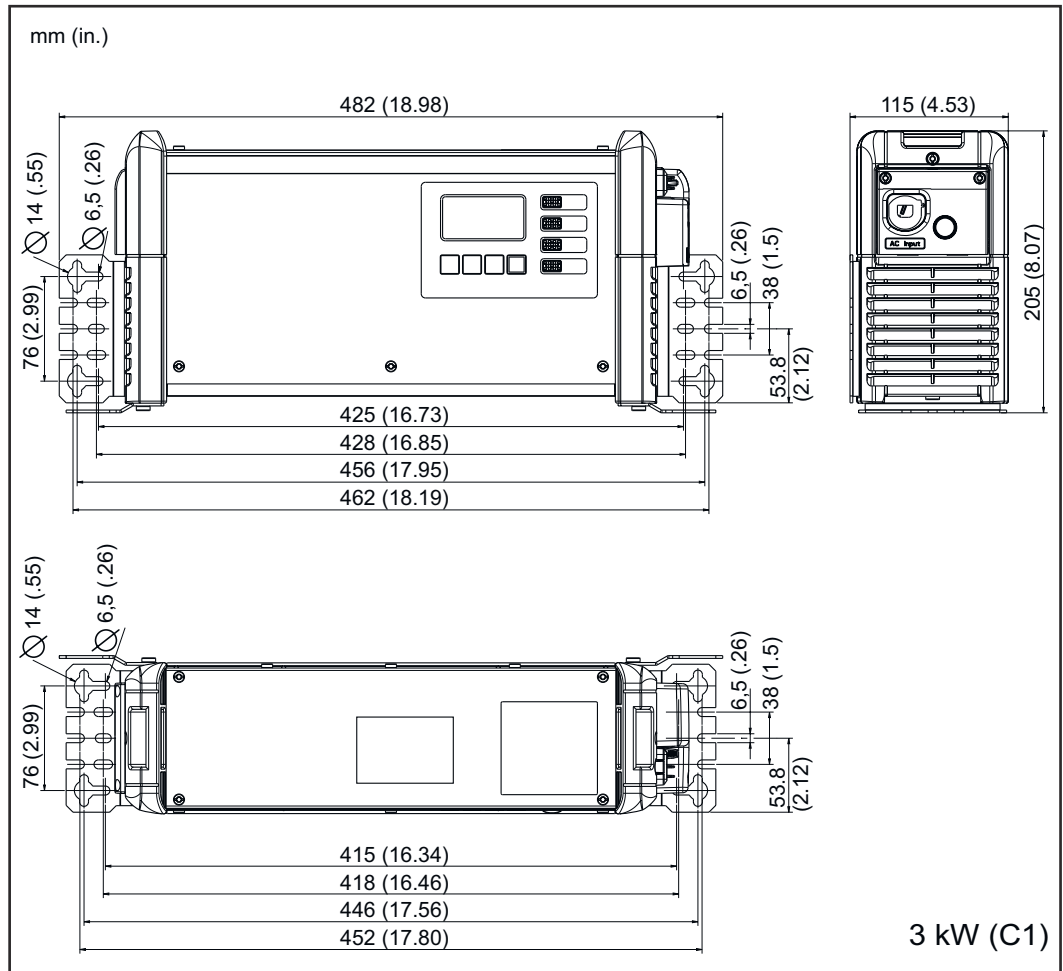

**Remote control system**

The remote control system allows full operation of the device from a distance of up to 30 m (98 ft., 5.1 in.). This option contains a full control panel in an aluminum housing with degree of protection IP42.

**Gateway Link**

The Gateway Link enables the easy connection of the gateway to the battery charger. The gateway can be connected without opening the battery charger.

**Gateway**

The gateway is the link between the battery charger and Charge&Connect. Detailed information can be found in the corresponding User Information.

# Technical data

## Selectiva 2 kW

Mains voltage <sup>1)</sup>	~ 230 V, ± 15%
Mains frequency	50/60 Hz
Mains fuse <sup>2)</sup>	max. 16 A
Minimum cross-section of the grid lead	1.5 mm <sup>2</sup> (0.002325 in. <sup>2</sup> )
Safety class	I (with ground conductor)
Max. permitted grid impedance Z <sub>max</sub> on PCC <sup>3)</sup>	None
Standby consumption	4.9 W
EMC device class	B
Dimensions l x w x h	341 x 110 x 198 mm (13.43 in. x 4.33 x 7.8 in.)
Pollution degree	3
Degree of protection <sup>4)</sup>	IP21
Overvoltage category	II
Operating temperature <sup>5)</sup>	-20°C to +40°C (-4°F to 104°F)
Storage temperature	-25°C to +80°C (-13°F to 176°F)
Relative humidity	max. 85%
Maximum altitude above sea level	2000 m (6561 ft.)
Mark of conformity	According to rating plate
Product standard	EN62477-1

- 1) The device may be operated on grids that are grounded at the neutral point.
- 2) The thermal rating of the automatic circuit breaker must not exceed 30,000 A<sup>2</sup>s.
- 3) Interface to a 230/400 V and 50 Hz public grid.
- 4) For indoor use only, must not be exposed to rain or snow.
- 5) At a high ambient temperature, a power reduction may occur (derating).

Device-specific data	Max. AC current	Max. AC power	Nominal voltage	Max. charging current	Weight <sup>6)</sup>
2040 2kW	7.9 A	1540 W	24 V	40 A	5.8 kg (12.79 lb.)
2050 2kW	9.9 A	1930 W	24 V	50 A	6.1 kg (13.45 lb.)
2060 2kW	12.0 A	2330 W	24 V	60 A	6.1 kg (13.45 lb.)

Device-specific data	Max. AC current	Max. AC power	Nominal voltage	Max. charging current	Weight <sup>6)</sup>
2070 2kW	12.1 A	2350 W	24 V	70 A	6.1 kg (13.45 lb.)
4020 2kW	7.9 A	1530 W	48 V	20 A	5.8 kg (12.79 lb.)
4035 2kW	11.9 A	2330 W	48 V	35 A	5.8 kg (12.79 lb.)

6) With standard grid and charging cable

### Selectiva 3 kW

Mains voltage <sup>1)</sup>	~ 230 V, ± 15%
Mains frequency	50/60 Hz
Mains fuse <sup>2)</sup>	max. 16 A
Minimum cross-section of the grid lead	1.5 mm <sup>2</sup> (0.002325 in. <sup>2</sup> )
Safety class	I (with ground conductor)
Max. permitted grid impedance $Z_{\max}$ on PCC <sup>3)</sup>	None
Standby consumption	
24 V devices	4.9 W
48 V devices	5.1 W
EMC device class	B
Dimensions l x w x h	417 x 110 x 198 mm (16.42 in. x 4.33 x 7.8 in.)
Pollution degree	3
Degree of protection <sup>4)</sup>	IP21
Overvoltage category	II
Operating temperature <sup>5)</sup>	-20°C to +40°C (-4°F to 104°F)
Storage temperature	-25°C to +80°C (-13°F to 176°F)
Relative humidity	max. 85%
Maximum altitude above sea level	2000 m (6561 ft.)
Mark of conformity	According to rating plate
Product standard	EN62477-1

- 1) The device may be operated on grids that are grounded at the neutral point.
- 2) The thermal rating of the automatic circuit breaker must not exceed 30,000 A<sup>2</sup>s.
- 3) Interface to a 230/400 V and 50 Hz public grid.
- 4) For indoor use only, must not be exposed to rain or snow.

5) At a high ambient temperature, a power reduction may occur (derating).

<b>Device-specific data</b>	<b>Max. AC current</b>	<b>Max. AC power</b>	<b>Nominal voltage</b>	<b>Max. charging current</b>	<b>Weight <sup>6)</sup></b>
2080 3kW	15.1 A	3040 W	24 V	80 A	8.2 kg (18.08 lb.)
2100 3kW	15.3 A	3290 W	24 V	100 A	8.2 kg (18.08 lb.)
2120 3kW	15.5 A	3340 W	24 V	120 A	8.7 kg (19.18 lb.)
4045 3kW	15.0 A	3250 W	48 V	45 A	7.4 kg (16.31 lb.)
4060 3kW	15.2 A	3280 W	48 V	60 A	7.4 kg (16.31 lb.)

6) With standard grid and charging cable



**Fronius International GmbH**

Froniusstraße 1  
4643 Pettenbach  
Austria  
contact@fronius.com  
www.fronius.com

Under [www.fronius.com/contact](http://www.fronius.com/contact) you will find the addresses of all Fronius Sales & Service Partners and locations.